The background of the cover is a composite astronomical image. It features a dark sky filled with stars, a vibrant green aurora borealis in the upper half, and a bright meteor streaking across the lower half. The overall color palette is dominated by deep blues, blacks, and the bright green of the aurora.

The Journal of The Royal Astronomical Society of Canada
Journal
Le Journal de la Société royale d'astronomie du Canada

PROMOTING
ASTRONOMY
IN CANADA

June/juin 2013

Volume/volume 107

Number/numéro 3 [760]

Inside this issue:

Kepler's Supernova

Discovery Channel
Telescope

Spectroscopy for Amateurs

Winter Star Party 2013

Processing Hubble Data

International Meteor
Conference

Solar Eclipse Crossword

Dark-Sky Treasure in
Eastern Ontario

Fire, Ice, and a Meteor

Astrophotographers take note!

This space is reserved for your B&W or greyscale images. Give us your best shots!

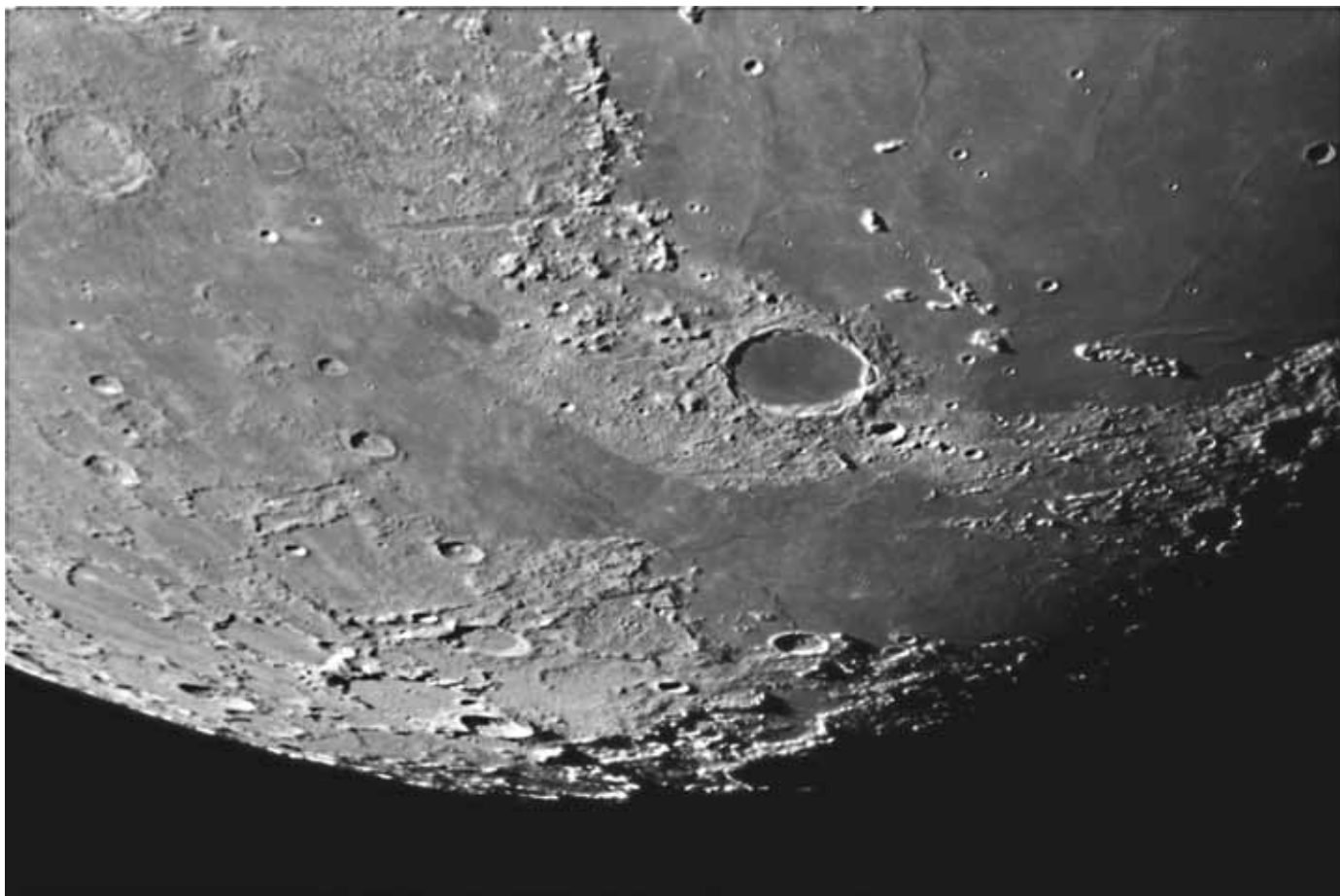

It's not an unusual image, but it is an unusual telescope. Klaus Brasch took this image of Plato and its surroundings using the 24-inch Clark refractor at Lowell Observatory in Flagstaff, Arizona. In his words, "Despite its considerable residual chromatic aberration, this venerable 120-year-old instrument works superbly when closed down to 18-22 inches, especially in B&W." This image is a stack of 10 exposures taken with a Canon 50D at ISO 800 under fair seeing.

contents / table des matières

Feature Articles / Articles de fond

- 103 **Kepler's Supernova and Shakespeare's *All's Well***
by Peter D. Usher
- 105 **Lowell Observatory and its New Discovery Channel Telescope**
by Klaus Brasch, Tom Vitron, and Stephen Levine
- 108 **Spectroscopy for Amateur Astronomers**
by Matthew Buynski
- 110 **Halifax RASCals at the Winter Star Party 2013**
by Dave XVII Chapman
- 114 **Armchair Astrophotography: Processing *Hubble* Data**
by Lynn Hilborn
- 115 **Spanish Island Haven Serves as Locale for International Meteor Conference**
by Andrew I. Oakes
- 117 **Solar Eclipse Crossword**
by Naomi Pasachoff
- 120 **Lennox & Addington County: A Dark-Sky Treasure in Eastern Ontario**
by Rob Plumley

Columns / Rubriques

- 121 **Cosmic Contemplations: Music of the Spheres**
by Jim Chung
- 123 **Imager's Corner: The Noise about Noise**
by Blair MacDonald
- 128 **On Another Wavelength: Lunar Swirls**
by David Garner
- 129 **Through My Eyepiece: Binoculars or Telescope?**
by Geoff Gaherty
- 130 **Rising Stars: The Thirty-Metre Telescope—One World in Search of Many**
by John Crossen
- 132 **Cheap Stuff From China: Power-Distribution Box**
by Rick Saunders
- 134 **Second Light: A Revolution in Astronomy**
by Leslie J. Sage

Departments / Départements

- 98 **News Notes/En manchettes**
compiled by Andrew Oakes
- *Mars simulation in Moroccan desert tests technology for future mission*
 - *Vortex on cloudy Venus shows chaotic action around South Pole*
 - *International Year of Water values increased cooperation of water sustainability*
 - *Third-closest star system gives Sun a new neighbour*
- 118 **Pen & Pixel**
Propeller Nebula / Comet PanSTARRS / Orion and Barnard's Loop / M81
by Joel Parkes / Stan Runge / Dalton Wilson / Blair MacDonald
- 135 **Reviews / Critiques**
A More Perfect Heaven: How Copernicus Revolutionized the Cosmos / Rock Star: Adventures of a Meteorite Man / Destination Mars
- 138 **Society News**
by James Edgar
- 139 **Great Images: Copernicus**
by Michael Wirths and the Lunar Orbiter
- 140 **Astrocryptic**
by Curt Nason
- 140 **It's Not All Sirius—Cartoon**
by Ted Dunphy

Front cover — Front Cover image: Shannon Bileski joined members of the Winnipeg Centre at a photographic outing to record Comet PanSTARRS and instead caught this spectacular meteor and a strong auroral display over the frozen waves of Lake Winnipeg. Shannon used a Nikon D800 at ISO 800 with a 24-mm-focal-length lens at $f/3.2$ for this 8-second exposure.



Journal

The *Journal* is a bi-monthly publication of The Royal Astronomical Society of Canada and is devoted to the advancement of astronomy and allied sciences.

It contains articles on Canadian astronomers and current activities of the RASC and its Centres, research and review papers by professional and amateur astronomers, and articles of a historical, biographical, or educational nature of general interest to the astronomical community. All contributions are welcome, but the editors reserve the right to edit material prior to publication. Research papers are reviewed prior to publication, and professional astronomers with institutional affiliations are asked to pay publication charges of \$100 per page. Such charges are waived for RASC members who do not have access to professional funds as well as for solicited articles. Manuscripts and other submitted material may be in English or French, and should be sent to the Editor-in-Chief.

Editor-in-Chief

Jay Anderson
203 - 4920 Dundas St W
Toronto ON M9A 1B7, Canada
Email: editor@rasc.ca
Web site: www.rasc.ca
Telephone: (416) 924-7973
Fax: (416) 924-2911

Associate Editor-in-Chief

Nicole Mortillaro
Email: nmortillaro@gmail.com

Associate Editor, Research

Douglas Hube
Email: dhube@phys.ualberta.ca

Associate Editor, General

Michael Attas
Email: attasm@aecl.ca

Assistant Editors

Michael Allen
Martin Beech
Dave Chapman
Ralph Chou
Ralph Croning
Dave Garner
Patrick Kelly
Gail Wise

Editorial Assistant

Suzanne E. Moreau
Email: semore@sympatico.ca

Production Manager

James Edgar
Email: james@jamesedgar.ca

Contributing Editors

Jim Chung (Cosmic Contemplations)
John Crossen (Rising Stars)
Ted Dunphy (It's Not All Sirius)
Geoff Gaherty (Through My Eyepiece)
Dave Garner (On Another Wavelength)
Blair MacDonald (Imager's Corner)
Curt Nason (Astrocryptic)
Andrew I. Oakes (News Notes)
Randall Rosenfeld (Art & Artifact)
Leslie J. Sage (Second Light)
Rick Saunders (Cheap Stuff From China)
David Turner (Reviews)

Proofreaders

Ossama El Badawy
Margaret Brons
Angelika Hackett
Terry Leeder
Kim Leitch
Suzanne Moreau

Design/Production

Michael Gatto, Grant Tomchuk
Email: gattotomatto@eastlink.ca,
granttomchuk@eastlink.ca

Advertising

Melissa Mascarin
Email: mempub@rasc.ca

Printing

Canselmdc
www.cansel.ca

The *Journal* of The Royal Astronomical Society of Canada is published at an annual subscription rate of \$93.45 (including tax) by The Royal Astronomical Society of Canada. Membership, which includes the publications (for personal use), is open to anyone interested in astronomy. Applications for subscriptions to the *Journal* or membership in the RASC and information on how to acquire back issues of the *Journal* can be obtained from:

The Royal Astronomical Society of Canada
203 - 4920 Dundas St W
Toronto ON M9A 1B7, Canada
Email: nationaloffice@rasc.ca
Web site: www.rasc.ca
Telephone: (416) 924-7973
Fax: (416) 924-2911



Canadian Publications Mail Registration No. 09818

Canada Post: Send address changes to 203 - 4920 Dundas St W, Toronto ON M9A 1B7

Canada Post Publication Agreement No. 40069313

We acknowledge the financial support of the Government of Canada through the Canada Periodical Fund (CPF) for our publishing activities.

Canada

© 2013 The Royal Astronomical Society of Canada.

All rights reserved. ISSN 0035-872X



News Notes / En manchettes

Compiled by Andrew I. Oakes

(copernicus1543@gmail.com)

Mars simulation in Moroccan desert tests technology for future mission

Forty-four years after the first human landing on the Moon, the world community is now one step closer to a future, manned, Mars-exploration mission. Twenty-three nations and more than 100 scientists participated in MARS2013, Europe's largest Mars Simulation experiment to date. The simulation saw a 10-member core expedition team conduct 17 scientific experiments during a 4-week-long mission.

The mission was lead by the Austrian Space Forum (Österreichisches Weltraum Forum, OeWF), a European organization that serves both as a national network for aerospace specialists and space enthusiasts and a communication platform between the space sector and the public. OeWF concluded its two-campsite Mars simulation in the Moroccan desert on February 28.

The simulation included field tests of two experimental spacesuits, an astronaut injury scenario, and tests of autonomous rovers and a cliff-climbing robot. The field tests

The Royal Astronomical Society of Canada

Vision

To inspire curiosity in all people about the Universe, to share scientific knowledge, and to foster collaboration in astronomical pursuits.

Mission

The Royal Astronomical Society of Canada (RASC) encourages improved understanding of astronomy for all people, through education, outreach, research, publication, enjoyment, partnership, and community.

Values

The RASC has a proud heritage of excellence and integrity in its programs and partnerships. As a vital part of Canada's science community, we support discovery through the scientific method. We inspire and encourage people of all ages to learn about and enjoy astronomy.



Figure 1 – MARS2013 simulation of Mars landing (in the Moroccan desert). Image: (c) OeWF (Katja Zanella-Kux)

concluded successfully, surpassing the initiative’s ambitious objectives according to a lead organizer, who referred to the international collaboration as “a global orchestra working simultaneously on a number of experiments!”

The analogue astronauts, who wore experimental spacesuits named Aouda.X and Aouda.S, were guided by a Mission Support Centre in Innsbruck and its partner organization, Kiwinspace, in Wellington, New Zealand. Mission control centres in Warsaw and Budapest commanded the robotic rovers MAGMA and Puli via a satellite connection.

In recognition of MARS2013’s spirit of exploration, the expedition’s two simulation camps were named after Carl Weyprecht and Julius Payer, two scientists who led a successful Austrian-Hungarian expedition to the North Pole from 1872 to 1874.

The set-up of Camp Weyprecht, the mission’s base camp, was followed 2 weeks later with a small 4-person team that undertook a 3-day excursion to a second location, where it established a secondary “landing site,” Camp Payer, 50 km south of Camp Weyprecht. According to an Austrian Space Forum media release, “the team took geological samples at different locations near the site, collecting dozens of bags of mineral samples for later analysis. The activity provided a challenging test of the logistics and communication that would be required for an analogous activity on Mars.”

The Austrian Space Forum reported that one of the biggest challenges during the simulation was communication. “The camp and the analogue astronauts on “Mars” had to possess a high degree of autonomy—and patience. Every message or question included the 10-minute delay that a real communication from Mars would take to arrive at Earth, resulting in a 20-minute turnaround time for a response from Mission Control. An important part of the mission, therefore, was the analysis of procedures for an emergency on Mars.

“On February 21, the team took part in a simulation scenario in which the analogue astronauts experienced an accident resulting in injury. The astronauts communicated the emergency to Mission Support and subsequently deployed an emergency tent developed by the Technical University Vienna. The Deployable Shelter is stowed in a backpack-sized case and, in the event that a single or a small group of astronauts are caught in a dangerous situation away from their base, can provide protection from the elements until help arrives.”

“The field test of the Deployable Shelter was successful. By the time the delayed response came from the Mission Support Centre in Innsbruck (Earth), the analogue astronauts were safely inside the shelter and rescue from the Weyprecht camp was on its way,” said a media release.

The spacesuits faced a serious challenge from the wind and sand of the Moroccan desert, as the blowing sand acted like

abrasive paper and presented an added stress on the suits. “The sand entered the suit through the air filter and affected the ventilation,” said the media release.

The MARS 2013 included two teams of robotic explorers.

“Google Lunar X PRIZE competitors, Team Puli, carried out tests of their rover prototype to demonstrate its reliability on extreme, hard terrain and its capability to be operated remotely from a mission control centre in Budapest Town Hall. ABM Space Education & Mars Society Poland’s Magma White rover tested a range of instruments including the LIFE laser to detect organic materials,” said the release.

“At one point, the two rovers performed an elegant waltz in the desert for two and a half hours as the two project teams remained in contact with each other and coordinated the movements and maneuvers of the rovers.”

Since the end of the simulation, scientists have processed, evaluated, and analyzed the collected data and held a scientific workshop in May in Vienna to discuss the results of the MARS2013 mission.

Vortex on cloudy Venus shows chaotic action around South Pole

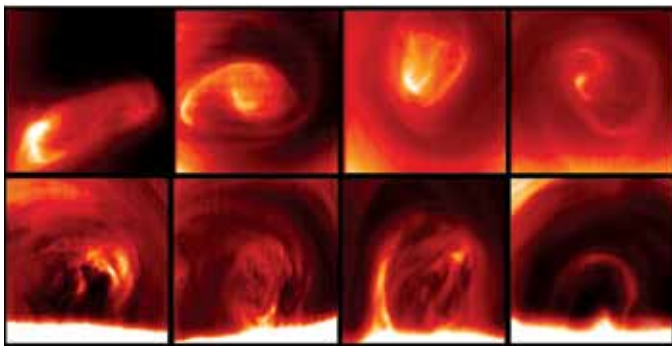

Figure 2 — Top: the upper cloud of Venus, 65 km above the planet’s surface. Bottom: the south polar vortex of Venus at 42 km, showing the vertical extension and variability of the vortex. Image: © Grupo de Ciencias Planetarias, UPV/EHU.

Polar vortices have been known for some time on Venus but new observations show that they have an unexpected structure and complexity. Using infrared images that reveal the cloud structure at two separate levels in the planetary atmosphere—42 and 63 km—European researchers have characterized the circulation patterns at these two levels in the Cytherean atmosphere. They have found that the vortices are highly variable, and the two levels seem to be largely independent of each other. Structures form and decay continuously; the patterns can be stable over periods of ten days or change dramatically in just one day.

“We knew it was a long-term vortex; we also knew that it changes shape every day. But we thought that the centres of

the vortex at different altitudes formed only a single tube, but that is not so. Each centre goes its own way, yet the global structure of the atmospheric vortex does not disintegrate,” explained Itziar Garate-Lopez, head researcher and member of the University of the Basque Country Planetary Science Group in a quote from phys.org.

The images used in the study were collected using the VIRTIS-M (Visible and InfraRed Thermal Imaging Spectrometer) on board the European Space Agency’s *Venus Express* orbiter. The VIRTIS instrument provides spectral images at different levels of the atmosphere and allows the observation of both the lower and upper clouds of Venus.

The study outlined the following characteristics of the vortex:

- The large-scale cyclone extends vertically in Venus’s atmosphere over more than 20 kilometres, through a region of highly turbulent, permanent clouds.
- The centres of rotation at two different altitude levels (42 and 62 km above the surface) are not aligned and both wander around the south pole of the planet with no established pattern, at velocities of up to 55 km/h.
- The vortices form within an environment of strong vertical wind shear, increasing by as much as 3 km/h for every kilometre of height; shears of this magnitude point to the possibility of atmospheric instabilities.
- The upper vortex is frequently double lobed.
- The vortices are trapped in polar regions by a wide, shallow collar of cold air.
- A tropopause at ~60 km altitude seems to separate the upper vortex from the lower.

Scientists are unable to explain why the vortex is able to alter its shape in just one day, or remain stable for weeks. A more precise explanation of the vortex and its relationship with the atmospheric superrotation is still awaiting further scientific analyses.

International Year of Water values increased cooperation of water sustainability

Mars, the Moon, Mercury, and the Jovian (specifically Europa) and Saturnian moons are not the only Solar System bodies where scientists hold an extreme interest in their water content. Planet Earth, the third “rock” from the Sun, holds a significant amount of water. However, in freshwater form, Earth’s water is not as plentiful as generally presumed. In reality, it is rather scarce: less than three percent of it is fresh water, and of that, more than two-thirds is locked up in glaciers and icecaps.

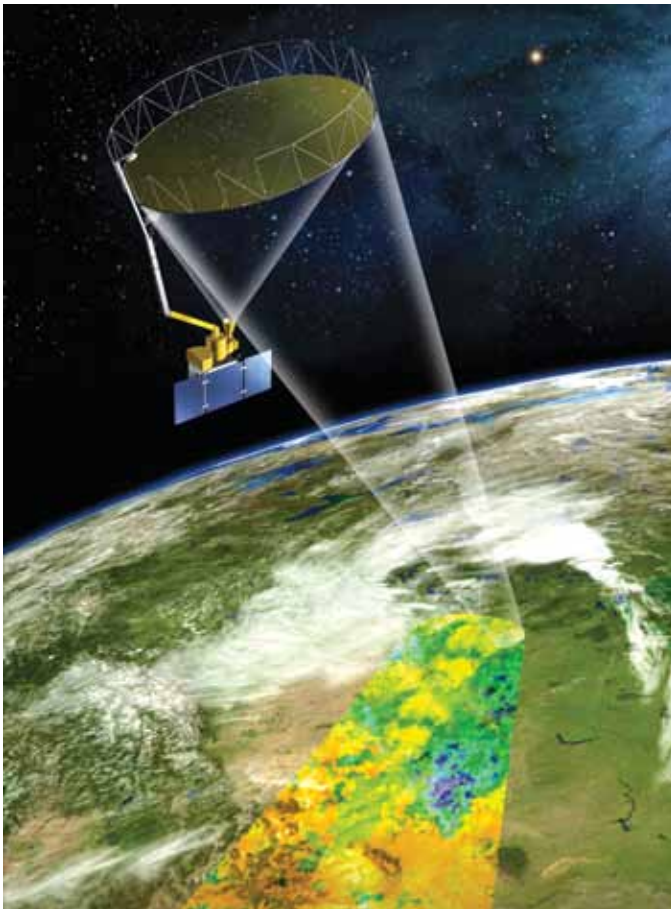

Figure 3 — NASA's Soil Moisture Active Passive mission, launching in 2014, will measure how much water is in the top layer of Earth's soil to help better understand and manage water resources. Image: NASA/JPL-Caltech

World Water Day is celebrated annually on March 22 to focus attention on the importance of freshwater and to advocate for the sustainable management of Earth's precious freshwater resources. This year, a special year-long celebration aimed at raising awareness of the potential for, and value of, increased cooperation in relation to water.

According to a JPL scientific-based acknowledgement of World Water Day, the Jet Propulsion Laboratory noted that scientists and many of its Earth missions are busy studying Earth's water and the complex interactions between water and the atmosphere, land, and living organisms that make up our dynamic Earth system.

NASA offered the following comments from its scientists, who were asked to reflect on World Water Day and the importance of studying the planet Earth's water:

During this decade, we will see come to fruition the capabilities to monitor nearly every component of Earth's freshwater—from the snow and ice at the poles and in our mountains to the groundwater deep beneath our feet, and all that lies between, such as water vapour, clouds and precipita-

tion in the atmosphere and stream flow and soil moisture on the ground. As the demand for this precious resource increase[s] with population growth and societal and ecosystem vulnerabilities change and/or grow in conjunction with climate change, these capabilities will become vital to maintaining our thriving society.

– Duane Waliser, JPL chief Earth scientist

We are now able to see from space all parts of the water cycle on land—rain and snow, evapotranspiration, soil moisture and deep groundwater, and NASA has another satellite mission on its way to detect river runoff: Surface Water and Ocean Topography, or SWOT. We're combining all these 'eyes on Earth' to make better predictions of water resources, droughts and floods.

– Josh Fisher, JPL research scientist

Since 2002, NASA's twin Gravity Recovery and Climate Experiment (GRACE) satellites have been monitoring large-scale groundwater depletion all over the globe. In northwest India, the Middle East, and also close to home in California's Central Valley aquifer, a significant fraction of the water needed to farm comes from groundwater. With GRACE, we have a tool that allows us to very accurately detect where and how much water is pumped from deep below—unfortunately, often at unsustainable rates. For example, during the 2006-to-2010 California drought, the equivalent volume of an entire Lake Mead was extracted from the Central Valley Aquifer!

– Felix Landerer, JPL research scientist

The Surface Water and Ocean Topography (SWOT) satellite mission planned for launch in 2020—jointly developed and managed by NASA, the French Space Agency (CNES), and the Canadian Space Agency (CSA)—will make measurements of the inventory of lakes and the discharge of rivers that are key to understanding the global water cycle on land; studying the dynamics of floodplains and wetlands, which have important impact on flood control and the balance of ecosystems; and providing a global assessment of water resources, including transboundary rivers, lake and reservoir storage and river dynamics.

– Lee-Lueng Fu, JPL senior research scientist, SWOT mission project scientist

Third-closest star system gives Sun a new neighbour

Kevin Luhman, an associate professor of astronomy and astrophysics at Penn State University and a researcher in Penn State's Center for Exoplanets and Habitable Worlds, has discovered the third-closest star system to our Sun, at a distance of only 6.5 light-years. The two stars in the newly

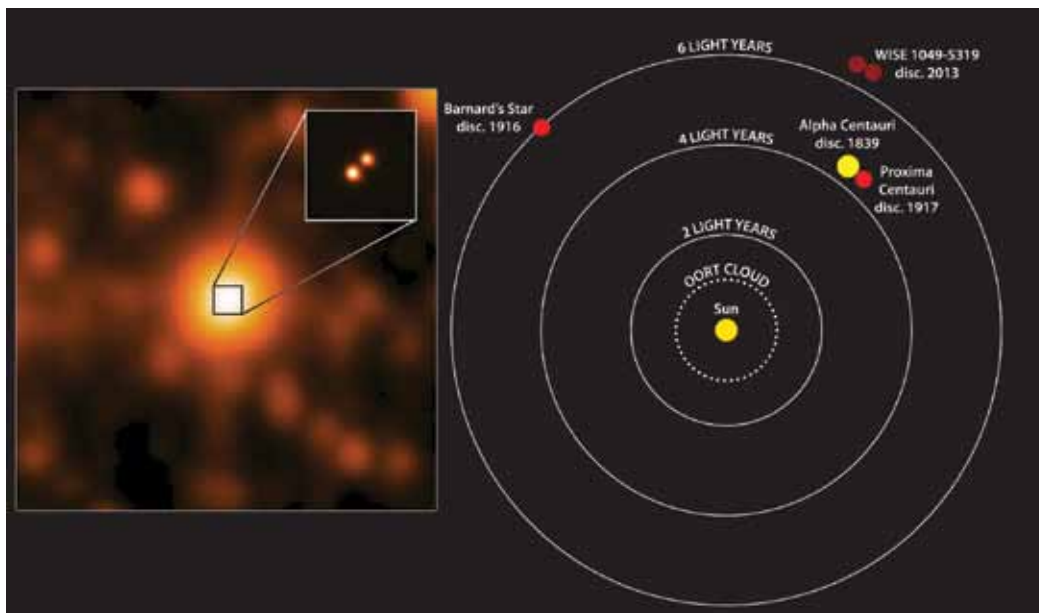

Figure 4 — Left: WISE 1049-5319 is at the centre of the larger image taken by WISE, the inset shows sharper image from Gemini Observatory (NASA / JPL / Gemini Observatory / AURA / NSF). Right: this diagram illustrates the locations of the star systems that are closest to the Sun (Janella Williams / Penn State University)

fusion. They are very cool and dim, and resemble a giant planet like Jupiter rather than a bright star like the Sun.

The system, named WISE J104915.57-531906, was discovered in images collected by the *Wide-field Infrared Survey Explorer* (WISE) satellite during a 13-month period ending in 2011. Barnard's star, the second-closest star, at 6 light-years from the Sun, was discovered in 1916. The closest star system, Alpha Centauri, was found to be a 4.4 light-year-distant neighbour in 1839, while its companion, the fainter Proxima Centauri, was discovered to be next door to us, at 4.2 light-years, in 1917. ★

discovered binary system are brown dwarfs—stars that are too small in mass to ever become hot enough to ignite hydrogen

Andrew I. Oakes, a long-time Unattached Member of RASC, lives in Courtice, Ontario.



SkyShed POD MAX

**Now completing development
and launching shortly!**

- Rugged construction (Built like a tank) 5.5" thick walls
- 6' 4" high wall with 32" wide door and a deadbolt lock
- Most affordable medium-sized dome ever
- Easy to assemble
- Multi configurations with POD MAX Bays and Dome only option
- Manual control to remote control
- Electronics by Kendrick Astro Instruments
- Designed for astro photography, education, and research
- Perfect for schools, clubs, and individuals with large scopes
- Ships to your door
- Prices estimated at 4K – 10K depending on model and level of automation
- 12.5' dome with traditional slot design, 44" wide opening
- 20 degrees past zenith view



**Made in Canada for
world wide export**

For more information please visit:

www.skyshedpodmax.com

is “particular” because it was a rare phenomenon and attracted a great deal of attention; and it was a “star,” because, like SN1572, it was starlike in appearance and appeared fixed among the other stars on the celestial sphere (Drake 1978, 104–5).

In *All's Well*, Helen's fixation on SN1604 plays out for the duration of the play, just as the Ghost in *Hamlet* that appears from the direction of SN1572 is central to the structure of that plot. Just as the identification of SN1572 is confirmed by subsequent events in *Hamlet* (Usher 2010, 100–107), so we expect that the present identification of SN1604 will be validated by ensuing developments in *All's Well*. In fact, 12 lines after Helen invoked the bright particular star, the script delivers the necessary confirmation.

Immediately after Helen has finished analogizing Bertram to a bright particular star, a soldier Paroles enters, whom Helen defines as foolish, mendacious, and cowardly. Paroles is decked out in outlandish garb, and he talks a good line. His appearance is comedic, as is his choice of a conversational topic. He is not supposed to have overheard Helen's soliloquy on her love for Bertram, yet straightaway he asks Helen whether she is meditating on virginity. His obsession is amusing, but it “has puzzled commentators” (Hunter 2000, p. xli).

When it comes time for Paroles to leave, his farewell is patronizing. “If I can remember thee, I will think of thee at court,” he tells Helen. But she is equal to the challenge, and her rejoinder only seems complimentary. “Monsieur Paroles, you were born under a charitable star,” she says. Paroles takes the bait, and the pusillanimous warrior cannot resist adding that he was born “Under Mars,” which is a reference to the Roman god of War. Helen seizes the opening. “I especially think *under* Mars,” she says, emphasizing the word *under*. The emphasis puzzles Paroles. “Why *under* Mars?” he asks, to which Helen explains: “The wars hath so kept you under that you must needs be born under Mars.” Once again, Paroles' addiction to self-promotion gets the better of him: “When [Mars] was predominant,” he says, but Helen's rejoinder scores the equalizer: “When he was retrograde, I think rather, [because you] go so much backward when you fight.”

Helen alludes to the retrograde motion of planet Mars, where in astronomical usage, “retrograde” refers to apparent angular motion in the opposite direction of the Sun around the ecliptic, *i.e.* from east to west relative to the background stars. In reality, in the heliocentric model of Nicholas Copernicus (1473–1543), the Earth overtakes Mars every 780 days (≈ 26 months) because Earth moves more swiftly and in a smaller orbit. Mars is then closest to Earth and at its brightest, and thus prominent in the night sky. Over a period of weeks and months, Mars appears to reverse its direction of motion, even though, of course, a hypothetical observer located among the stars would see Mars continue to go around the Sun in the same sense as the Earth. This gives Shakespeare a perfect

opportunity to exemplify the “dilemma most persistent in Shakespeare—that of appearance and reality” (Hunter 2000, p. xl).

Other meanings of the verb “to retrogress” listed in the *Oxford English Dictionary*, and prevalent in the early modern age, are: “to turn back,” “to reverse,” “to retrace one's steps,” or “to return along a former course.” The emphatic reference to Paroles (*i.e.* Mars) retrogressing (*i.e.* retracing his steps), and the fact that Helen refers to Paroles' past endeavours, suggests that we turn back the clock and let Mars retrace its steps. The starting time of the retrogression is likely to be the date on stage at the time, which as posited, is the date of the first sighting of SN1604, 1604 October 9. We discover that Mars undergoes retrograde motion from 1604 March 1 to May 19, and remarkably, it does so across the constellation Virgo, the Virgin (Figure 2). It is not coincidental that the immediately preceding dialogue between Helen and Paroles is a lengthy discourse on virginity, and that both contain starry conceits.

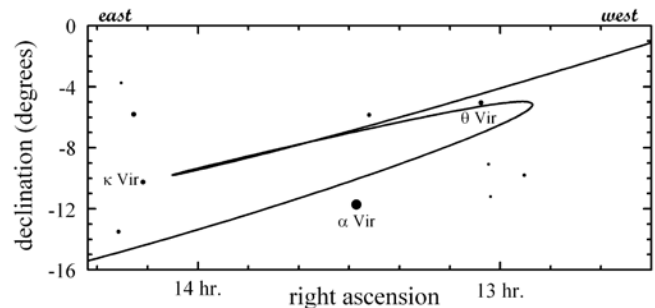

Figure 2 — Mars moves progressively from west to east (right to left on the chart) relative to the background stars, but from 1604 March 1 to May 19, it moved retrograde from east to west, before resuming its prograde motion. The looping occurs across the constellation Virgo, whose brightest star is α Virginis (Spica). The period covered on the chart is from 1603 December 24, to 1604 July 30. (Data from Voyager 4.0.6 by Carina Software © 1990–2008.)

There is additional support for the mooted identification. As posited, the present argument dates the beginning of *All's Well* as the time of the first observation of SN1604, which sets an early limit of 1604 October 9 for the time of writing of the play. This lies well within the dates 1603–5 suggested by other arguments (Bate and Rasmussen 2011, 182; Hunter 2000, pp. xviii–xxv; Leggatt 2003, 10–11; Snyder 1993, 24). The prior and next intervals when Mars undergoes retrograde motion are 1602 January to April, and 1606 April to July, neither of which occurs in the foreground of Virgo and both of which lie outside the commonly accepted range of writing.

Helen associates Bertram with SN1604 and Paroles with Mars, so the two roles are associated with celestial phenomena. The nobleman Bertram has the superior position relative to the commoner Paroles, just as a star fixed on the celestial sphere of the stars has a superior position to any foreground planet.

Both Bertram (as SN1604) and Paroles (as Mars) are flawed according to the rubric of Aristotelian philosophy (and their flaws are quite evident as the play progresses), because the phenomena they represent violate the old dogma of celestial perfection, the former owing to the violation of the dictum that the sky be perfect and therefore unchanging, and the latter because retrograde motion is a flagrant violation of the dictum that celestial sources are supposed to move prograde across the celestial sphere.

Finally, in the next scene 1.2, “catastrophe” and “heel” occur in the same line (1.2.57), and in the scene after that, we find the word “serpent” (1.3.141). Shakespeare writes always to a purpose, yet these occurrences are seemingly unwarranted by context. Probably, they refer to the new star that erupted, as if catastrophically, in the heel of Ophiucus, the Serpent-Bearer, which Kepler in his treatise *De stella nova in pede Serpentarii* called the Serpent.

Is SN1604 the only option? Helen says that the candidate must be bright, particular, starlike, and “far above me.” In olden days, “star” meant any celestial light source, and the next best guess for an exceptionally bright object is the Sun. But, in the ancient model of the Universe, the Sun’s orbit lies inside the orbits of Saturn, Jupiter, and Mars, and is therefore not particularly far above the Earth. Another candidate at high altitude would be Saturn, which is next highest compared to SN1604, and could be regarded as particular because it is the slowest of the planets to complete a circuit of the celestial sphere. But, Saturn is not particularly bright as it reaches an apparent magnitude of only -0.5 , which is fainter than the two brightest stars in the sky (Sirius and Canopus). ★

References

- Bate, Jonathan & Rasmussen, Eric (2011). *All’s Well That Ends Well*. By William Shakespeare. New York: Modern Library.
- Berry, Arthur (1961). *A Short History of Astronomy (1898)*. New York: Dover.
- Christianson, John R. (2000). *On Tycho’s Island: Tycho Brahe and his Assistants*. Cambridge: Cambridge University Press.
- Drake, Stillman (1995). *Galileo at Work: His Scientific Biography* (1978). New York: Dover.
- Hunter, G.K., ed. (2000). *All’s Well That Ends Well*. By William Shakespeare. London: Arden Shakespeare.
- Leggatt, Alexander (2003). Introduction. In Russell Fraser, (Ed.), *All’s Well That Ends Well*. (pp. 1–43). By William Shakespeare. Cambridge: Cambridge University Press.
- Olson, Donald W., Olson, Marilyn S., and Doescher, Russell L. (1998). The Stars of Hamlet. *Sky & Telescope* 96.5, 67–73.
- Snyder, Susan (Ed.) (1993). *All’s Well That Ends Well*. By William Shakespeare. Oxford: Oxford University Press.
- Usher, Peter D. (2010) *Shakespeare and the Dawn of Modern Science*. Amherst, NY: Cambria.

Lowell Observatory and its New Discovery Channel Telescope

by Klaus Brasch, Tom Vitron, and Stephen Levine
Lowell Observatory, Flagstaff, Arizona
(www.lowell.edu)

In addition to its breathtaking mountain scenery—including the soaring San Francisco Peaks and Sunset Crater National Monument—Flagstaff, Arizona, is home to a number of important astronomical landmarks. The region enjoys a high percentage of exceptionally clear, transparent nighttime skies, largely due to its average elevation around 2100 m and dry, semi-desert setting. Flagstaff also takes pride in being named the first International Dark-Sky Community in 2001 by the International Dark-Sky Association. Consequently, light pollution in the region is minimal and well contained, thanks to sensible lighting ordinances that keep regional skies pristine for astronomers and nature lovers alike.

Meteor Crater, the best-preserved impact basin on Earth, lies some 40 miles east of Flagstaff, a stark reminder that our planet has been, and will continue to be, the target of debris from space. As if to underscore that very possibility, the US Geological Survey’s Shoemaker Center for Astrogeology is also located in Flagstaff. Named after its founder, the late Eugene Shoemaker, the centre is a major hub of planetary research. Shoemaker, his wife Carolyn, and amateur astronomer David Levy, are probably best known for their discovery of the spectacular Comet Shoemaker-Levy 9, which struck Jupiter in 1994. Another important astronomical facility a few miles west of the city is the U.S. Naval Observatory’s Flagstaff Station. Important astrometric work and related research are carried out there with several telescopes including the 1.55-m Kaj Strand reflector.

The region’s prime astronomical attraction, however, is Lowell Observatory. Established in 1894 by Percival Lowell, a prominent Bostonian, it is among the oldest observatories in the United States, and was designated a National Historic Landmark in 1965. In 2011, the observatory was named one of “The World’s 100 Most Important Places” by *TIME* magazine. The original campus, perched atop Mars Hill at an elevation of 2200 m, has a commanding view of the region and welcomes some 80,000 visitors a year. In addition to a fine museum and visitor centre, numerous exhibits, and a gift shop, guests can tour the attractively landscaped campus during the day. They can see the telescope and photographic plates used to discover Pluto, and look through the venerable 120-year-old 24-inch Clark refractor used by Percival Lowell to study Mars and the other planets. Weather permitting, visitors can also enjoy observing with the Clark and many other telescopes at night (Figure 1).



Figure 1 — The venerable 24-inch Clark refractor in its wooden dome. (Except where noted, all images courtesy Lowell Observatory)

Lowell Observatory has made several major contributions to astronomy during its nearly 120-year history. Foremost among these are the discovery of the recession velocities of galaxies by Vesto Slipher in 1914, leading directly to Edwin Hubble's findings that the Universe is expanding, and of course, the discovery of Pluto by Clyde Tombaugh in 1930. More recent Lowell contributions to astronomy include the discovery of the rings of Uranus, the atmosphere of Pluto, establishment of one of the first near-Earth-object searches, and the detection of water vapour around an extra-solar planet, to name but a few. Pluto's largest moon, Charon, also has a Flagstaff connection: it was discovered in 1978 with the Strand telescope at the U.S. Naval Observatory's Flagstaff Station.

Despite Flagstaff's very commendable light-pollution control measures, the sky over the city is not as dark as it was. Because of that, Lowell's main research telescopes are located 15 miles south at a darker site on Anderson Mesa, which is also home to the Navy Precision Optical Interferometer (NPOI), operated in partnership with the U.S. Naval Observatory and the U.S. Naval Research Laboratory (Figure 2).

The most exciting new addition to the observatory's research facilities, however, is Lowell Observatory's Discovery Channel Telescope (DCT). The telescope began formal science operations at the start of 2013, and much of this year will be



Figure 2 — Aerial view of Lowell Observatory's Anderson Mesa dark site showing the NPOI array and several other telescopes.

spent in doing a combination of science and commissioning work. Located some 40 miles south of the city near Happy Jack, Arizona, the 4.3-m, state-of-the-art DCT is one of the largest telescopes in the United States. It was officially inaugurated on 2012 July 21 at a "first-light" gala at which astronaut Neil Armstrong, the first man on the Moon, was the featured speaker. Armstrong reminded everyone present that no one could have foreseen in 1959 the exciting scientific discoveries that the *Apollo* era ushered in, from which we are still benefitting today. Likewise, he felt, the DCT would open up new scientific horizons that only future generations will fully appreciate (Figure 3).



Figure 3 — Aerial view of the DCT dome and support buildings.

Perched atop a small cinder cone at an elevation of 2300 m, the DCT frequently enjoys sub-arcsecond seeing and excellent transparency. Using a classic Ritchey-Chrétien optical configuration, the telescope was designed to be multi-functional. It can accept a broad range of instruments for both wide-field survey work and high-resolution spectrometry in both visible and near-infrared light. The existing instrument cube can carry up to five instruments at one time (Figure 4). It takes about 30 seconds to switch the optical beam between instruments with retractable folding mirrors. The first instrument to be installed is the Large Monolithic Imager (LMI), which uses a single large CCD to cover a 12.3×12.3 arcminute field of view. This imager makes it easier to flat field and look for faint diffuse light around galaxies and other extended objects. A planned Near IR High Throughput Spectrograph (NIHTS) will use a dichroic element instead of a mirror to allow the NIHTS and LMI to be used simultaneously. The ability to acquire near-IR



Figure 4 — The DCT's 2×0.5 -metre instrument cube behind the primary mirror.

spectra and optical images at the same time of an object is quite unusual and should expand the range of science possibilities.

The DCT mount is a low-profile altazimuth design made by General Dynamics SATCOM and is capable of rapidly slewing to any part of the sky. The dome design allows unobstructed observing as low as 7.5 degrees above the horizon. The azimuth drive system uses four motors operated in two pairs, and elevation is driven directly by two motors for very smooth operation (Figure 5). For an overview of all technical details, see Levine *et al.* (2012).

Lowell and astronomers from partner institutions Boston University, and the Universities of Maryland and Toledo, will use the DCT to address some of the most basic questions about the Universe, including how the Solar System formed, how galaxies evolved, and how common are Earth-like exoplanets. These will include searches for Kuiper Belt Objects (KBOs), with recovery and follow-up, deep imaging around dwarf galaxies looking for extended gas and stellar components that have previously been missed, exoplanet transit work, and gravitational weak lensing associated with galaxy clusters. When new spectrographs are ready, including an updated DeVeney low- to mid-resolution optical spectrograph, the NIHTS, and RIMAS (a dual beam near-IR low- and high-resolution imaging spectrograph being built by Goddard Space Flight Center and the University of Maryland), the range of projects will expand dramatically to include object classification (*e.g.* KBO families, stellar classification, galaxy rotations, and internal stellar streaming, *etc.*).

Although the DCT is fully dedicated to astronomical research, unlike most other major telescopes today, one can actually look through it with an eyepiece! Through Discovery Channel, this state-of-the-art instrument will also play a role in promoting and educating the public about astronomy. Some of us have been fortunate enough to observe with several very famous telescopes over the years, including Lowell's classic 24-inch refractor, the 60-inch at Mt. Wilson Observatory, and the 74-inch at David Dunlap Observatory. Nothing, however, can compare to viewing Jupiter through a 4.3-m-aperture telescope at a magnification of 850 \times under pristine skies and rock-steady seeing. The planet's cloud belts were ablaze with festoons and colors, just as in a space-probe flyby. Even more



Figure 5 — Side view of the DCT inside its dome prior to installation of the instrument cube. Note the astronomer at right for scale. (Photo by M. Beckage)

compelling was Jupiter's moon Io, just beginning a transit and showing a perfectly round disk with dark and light surface detail clearly visible.

It will, of course, take some time to fine-tune and bring this newest addition to Lowell Observatory's suite of telescopes to full operational status. Nonetheless, research with it has already begun, and astronomers are delighted with the results so far. As the image of NGC 891 attests (Figure 6), the optical quality of the DCT is outstanding. ★



Figure 6 — DCT image of the striking edge-on galaxy, NGC 891. Courtesy Massey/Neugent/Dunham/Lowell Obs./NSF

References

- Levine *et al.* (2012). Status and performance of the Discovery Channel Telescope during commissioning. *Proc. SPIE 8444*, paper 844419.
- Lowell Observatory is a private, non-profit institution dedicated to astrophysical research and public appreciation of astronomy and operates the DCT in partnership with Boston University, the University of Maryland and the University of Toledo. Partial support of the DCT was provided by Discovery Communications and the LMI was funded by NSF grant AST-1005313.

Spectroscopy for Amateur Astronomers

by Matthew Buynoski
(buynoski@batnet.com)

Much of what we know about stars has been (and still is) being discovered by spectral analysis: radial velocities, rotation rates, chemical composition, pulsation, luminosity class, surface temperature, internal oscillations (in the Sun), *etc.* Because of the difficulties of making precise gratings and the overwhelming need for light, stellar spectroscopy until recently has been the domain of professional astronomers working with custom-built spectroscopes and very large telescopes. However, improvements in the manufacture of reasonably priced gratings and the CCD imaging revolution have changed that. CCDs have quantum efficiencies 50–100 times that of photographic film, making current amateur instruments of aperture 200–300 mm the effective equivalent of telescopes of aperture 1.5–3 m that were in use at the beginning of the 20th century. At that time, a great deal of real science was done on those instruments, and that level of research is now possible for the dedicated amateur.

Not into “heavy scientific” work? Just want to enjoy the colourful rainbows of other stars, or see the fascinating absorption-line detail in the solar spectrum? A number of options, some quite inexpensive, are available to display spectra for you.

Roughly four types of devices are available to the amateur astronomer. You can begin spectroscopy for about the cost of an eyepiece and, if your interest is aroused, you may advance to more sophisticated (and expensive) instruments. Almost all use some sort of diffraction grating, in either transmission or reflection mode.

Slitless eyepiece transmission gratings provide a small amount of spectral detail with bright stars: molecular bands in M-class stars, hydrogen lines (Balmer series) in many stars, and relative amounts of blue vs. red in the spectra of hotter and cooler stars. They need only a reasonably sized telescope (200-mm aperture or larger) to present a colourful spectrum at the eyepiece. If you have a larger telescope (50 cm and up) and a steady sky, then you can actually see some metallic lines in the spectra of the brightest stars, *e.g.* Capella.

Stellar spectra viewed at the eyepiece, even with only minimal detail, are a big hit at star parties. They are colourful (especially popular with children), and everyone readily relates to them as the “rainbow” of another star. The presence of absorption lines is a good lead into explanations of how scientists learn about stars, and the relative brightness of different colours (*e.g.* Rigel *vs.* Betelgeuse) reveals the different temperatures of stars in a simple way. All the eyepiece gratings I have used are threaded like a filter, and screw into either an eyepiece or the front of a

star diagonal. They are easy to use, and the cost is reasonable at \$100–250 US.

Handheld spectroscopes, with either gratings or prisms, can be used to project a low-resolution solar spectrum onto a white page (NEVER look through them directly at the Sun!), showing some of the more prominent absorption lines. They also show the emission spectra of fluorescent lamps, handy if you are showing all kinds of spectra (not just the Sun) to schoolchildren. They are very easy to use. Cost: \$50–300 US, but you will be better off avoiding the low end here.

Relatively high-resolution, stand-alone (no telescope required) spectroscopes display quite detailed solar spectra. The abundance of photons available from the Sun allows a much greater spreading out (dispersion) of the spectrum, thus separating and delineating literally hundreds of absorption lines in a colourful continuum background. Plan on having a dark-cloth observing hood when doing this kind of work; if the pupils of your eye are too contracted, holding your head in proper position relative to the light beam exiting the instrument is somewhat difficult. Use is simple—all you need is a photographic tripod with some decent slow-motion controls. Because the sunlight completely illuminates the slit of the spectrometer, such instruments are insensitive to seeing. Cost takes a big leap upward here: in the range \$1,000–3,000 US.

Spectroscopes used with a telescope and CCD detector can record detailed spectra of all kinds. Want to measure the rotation rates of Saturn or Jupiter while recording absorption lines related to their atmospheres? Place the slit of the spectroscope along the planets’ equators and record the tilt in the spectral lines due to rotational Doppler shifts. Double-star observers can sneer at Dawes’ limit as they record the separation and merging of spectral lines of spectroscopic binaries (a Doppler effect due to the orbital velocities of the stars), including quite a number of oddities. Variable-star observers can track not just brightness variations, but record the spectral changes that many variables undergo. For general observers, spectra of vast numbers of stars can be recorded; what was just “another bright dot” will acquire individual traits and, often, peculiarities.

Units capable of these kinds of results do come at a pretty steep cost: \$3,000–\$20,000 US. Some of these have the ability to accommodate comparison with calibration-lamp spectra and can be used for serious and precise investigations.

Most of the instruments form their spectra by using diffraction gratings having precisely spaced parallel lines on glass (transmission grating) or a mirror (reflection grating). Either can work, but you should be aware of a couple of factors that will affect what you see.

Generally, the more lines per mm on the grating, the higher the theoretical resolution, and the more detail is possible. Spectral lines separated by only a few Ångströms can be seen

as distinct from one another; however, the detector (your retina, or the pixels of a CCD) also has limits. To see all the theoretically predicted detail, it is necessary to spread out the spectrum adequately. If the wavelengths of several spectral lines all fall on the same pixel, for example, then they will of course be indistinguishable. So the physical length of the spectrum across the retina or CCD chip (*i.e.* its dispersion, usually expressed in the number of Ångströms impinging on a millimetre of detector width) is also important. The more you spread out a spectrum, the more the details are separated, but (unfortunately) the dimmer the spectrum becomes, as the same amount of light is covering a wider area. This is why so much light is needed for detailed spectroscopy.

The eye does not collect light over a long time, instead sending an image to the brain roughly every 1/20 second. Thus, you should not expect to see extremely detailed spectra visually. As you increase the dispersion, the spectra start to dim, lose colour (blues and reds go first), become ghostly gray (though you can still see some details), and eventually fade away. Therefore, relatively low-dispersion gratings are fine for direct viewing. The exception here is the solar spectrum, where the extravagant supply of photons allows very high dispersion.

CCD detectors can collect light over much longer time periods, but this requires accurate guiding to keep the stellar image on the spectroscope's entrance slit. For long exposure times, this will entail the same level of care as is necessary for astrophotography: an accurate tracking mount, guiding either by hand or by guide scope, periodic-error correction, and so on. A heavy-duty mount may be needed, as the spectroscope and camera combination is a heavier load than a camera alone.

Some vendors are listed below (with types available: A = slitless eyepiece-transmission gratings, B = handheld spectroscopes, either grating or prism, C = stand-alone spectroscopes, D = instruments aimed mainly for use with CCD cameras). All of these vendors have Web sites—alluring places that will tempt you to spend money.

Rainbow Optics (A) www.starspectroscope.com

Shelyak Instruments (ABCD) www.shelyak.com

Baader Planetarium (ACD) www.baader-planetarium.com

(D) www.sbig.com/products/spectrographs

(B) www.scientificsonline.com/spectroscope.html

Additional Reading

Practical Amateur Spectroscopy, Tonkin (ed.). Use of various instruments, from simple to sophisticated, plus some introductory theory. This is a very good book for getting started, and in many ways this brief article is a tickler to get you to read this book or the next.

Stars and Their Spectra, Kaler. Non-mathematical introduction to the application of spectroscopy to stellar astrophysics. With lots of detail and minimal math, Kaler does a good job of keeping the fascination factor high.

Astronomical Spectroscopy, Tennyson. Heavy on theory starting from quantum mechanics, this goes pretty deeply into the details of how both atomic and molecular spectral lines form. Pretty much requires that the reader knows something about quantum theory.

A Spectroscopic Atlas of Bright Stars, Martin. Gives an idea of what kind of stellar spectra one obtains with good amateur equipment. As a bright-star atlas, though, it has some unfortunate omissions, such as Canopus, Alpha Centauri, and Arcturus.

Optical Astronomical Spectroscopy, Kitchin. Theory and practice (mostly at the professional observatory level) of spectroscopy. Intermediate between Kaler and Tennyson, above, on the theory.

An Introduction to Modern Astrophysics, Carroll & Ostlie. Excellent textbook on many aspects of astrophysics, including spectroscopy. Of course, such an upper-level college textbook uses a lot of math, but it is more approachable than comparable volumes.

Kitt Peak National Observatory Atlas of the Solar Spectrum. Great detail on the absorption lines of our local G2V star. Also available to download from Kitt Peak as 145 postscript files; it is an extremely detailed solar spectrum, plus much other useful stuff.

The Sun from Space, Lang. Results from many of the orbiting solar observatories, including work on helioseismography, enabled by almost unbelievably precise solar spectroscopy. Fascinating reading.

Optics, Ghatak. Textbook, lots of theory, lots of math. One of many available optics texts that this author happens to own.

Stellar Spectral Classification, Gray and Corbelli. Very detailed look at the art and science of classifying stars from the information contained in their spectra, including myriad stellar peculiarities, methodological difficulties, and what unfinished business remains in the field. Not too mathematical most of the time (it has its moments), but still a technical work. ★

Matthew Buynoski is a now-retired chemical engineer who spent 37 years doing sophisticated semiconductor process development in Silicon Valley. He knows more than the average amateur about optics, materials science, solid state, and quantum physics, indulges in astronomy strictly as an amateur, and his spectral experience is largely with a Rainbow Optics eyepiece grating, a Shelyak Instruments Lhires Lite for the Sun, and handheld spectroscopes (both grating and prism).

Halifax RASCals at the Winter Star Party 2013

by Dave XVII Chapman, Halifax Centre
(dave.chapman@ns.sympatico.ca)

The Winter Star Party (WSP) is a six-night camping/observing event held in the dead of winter in the Florida Keys, organized by the Southern Cross Astronomical Society. In 2013, I travelled there with my wife, Chris, and joined fellow Halifax RASCals Dave VIII Lane, Greg Palman (our member in Maine), and Quinn Smith. I was the only “newbie” of this Gang of Four at WSP.



Figure 1 — The Winter Star Party is held on a beach campground in the Florida Keys (24° N). (All photos by Dave Chapman).

Night Zero: After dark, Chris and I finally arrive (via Montréal and Miami) at our chalet in Little Torch Key, following an eventful day that started with a 4 a.m. wakeup. So tired! Even from here (10 minutes away by car from the WSP site), the sky has a sky quality meter (SQM) reading of 21.2 magnitudes per square arcsecond, similar to Keji (Kejimikujik National Park). Our position is N 24° 40' W 81° 23'. It is Night Zero because we can't enter the site yet, and Dave VIII, Quinn, and Greg have yet to arrive. I nap and take the binoculars out later, having already seen brilliant Canopus in the south! (The sky is good, but there is too much glare from nearby lights—typical!) My first impression: it is wonderful to observe winter stars in summer clothes!

Night One: The Gang of Four finally convene at WSP, and we observe from dusk until 11:30 p.m. (all times EST), when a band of cloud intervenes. It is a quiet night, with many telescopes still under cover, likely because many people have travelled long distances and are sleeping it off. I tour the southern Milky Way with the famous discount 15×70 Celestron binoculars, including objects from Chris Beckett's new “Wide-Field Wonders” (WFW) observing list (p. 328 of the *Observer's Handbook 2013*). Some of these objects appear

to the naked eye as noticeable concentrations in the star field and open up in binoculars, but are too broad for typical telescopes unless the optics are specifically set up for wide-field views. I finally convince the others that the sky glow to the west is the Zodiacal Light, although light pollution from Key West may contribute at the lowest altitudes. The zenith SQM reading varies around 21.1, but is worse (lower) in directions of obvious light pollution.

When the wind dies, the telescopes present a jitter-free view of Jupiter in pretty good seeing conditions. We just miss an eclipse reappearance of Ganymede, but then all eyes are on the Great Red Spot (GRS). Much is learned from this experience, including the use of filters and the role of astigmatism



Figure 2 — The Gang of Four (Quinn Smith, Greg Palman, Dave XVII Chapman, and Dave VIII Lane)—we were happier than we look in this photo, “painted” with a red flashlight.

in the observer's eye (*i.e.* wear eyeglasses if your astigmatism is strong). The skies are not darker than the best Nova Scotian skies, but the mild weather allows us to observe the “winter” sky with a great deal of comfort, plus there are another 20 degrees of southern declination on offer and five more nights of it. There is a radio tower nearby to the north, but we did not come south to look north! I also have a bunk with the others in the “chickee” hut for naps and sleeping at the end of the night. Many other WSP participants are staying at the same resort as Chris and me, and we end up chatting with Al Nagler of Tele Vue over continental breakfast. Al asks me what I observed, and he shows a lot of interest in the WFW, as he feels his telescopes and eyepieces are up to it. Al encourages me to look for the asterism Nagler 1, which is not catalogued anywhere, but is included in the Tele Vue Sky Tour push-to software.

Night Two: This night is very similar to Night One, although now Dave VIII has his 333-mm (13-inch) *f*/4.5 travel Dob assembled (some missing essential parts were express-mailed to him!). We start out observing a GRS transit on Jupiter. I continue with more WFW, adding a few of my own from southern declinations in Hydra, Puppis, and Vela. I have been



Figure 3 — A wide-field photo of Crux (right) and α and β Centauri (left), taken at about 4 o'clock one morning. (Canon XSi, ISO 1600, 50-mm $f/1.8$ lens, 30s, untracked)

“reverse” observing, finding interesting smudges and concentrations by naked eye, investigating with binoculars, and then looking at the chart. Greg Palman brought his Astrophysics 130-mm (5-inch) $f/6$ triplet refractor on a GTO Mach 1 mount, and we easily follow up some objects by punching the object catalogue number into the controller. There are hundreds of people here, and they are spread in a band along the beachfront. It takes 20 seconds to walk across the width, and several minutes to traverse the length. I am sure this contributes to the low-key vibe of the event. There is no public observing; everyone on site is a paid participant or staff. Every so often, someone wanders by for a look or a chat. There are some interesting and well-known people around, but how to find them?

Night Three: The evening starts off partly cloudy and breezy, but warm. We meet Carlos, a Cuban friend of Alejandro Jimenez (my astronomy friend in Havana), now a U.S. resident. He is imaging at WSP. It is a great visit, and we talk a lot about Cuba and the astronomers we know there! We observe for a few hours, and then sleep until 2 a.m. The darkest portion of the sky reads 21.4 on the SQM. We watch Crux rise, then α and β Centauri, then Scorpius, then the Moon. We observe some of Alan Whitman’s “Southern Hemisphere Splendors” (p. 330 in the *Observer’s Handbook 2013*), but the

haze obscures them a little: ω Centauri (GC), the Jewel Box (OC), and the Carina Nebula (EN). The waning crescent Moon is at elongation 39° west of the Sun, and we try to memorize the Earthshine to compare on the next day.

Night Four: A clear night, but humid; even dew problems. We all watch a lovely GRS transit followed by an Io transit ingress and shadow transit ingress. The seeing is excellent, as are the views in Greg’s refractor. I take a few wide-field exposures with my Canon XSi camera on my MusicBox EQ mount, while Dave VIII and Greg image the Orion Nebula. With a little Internet research, I find the location of the Nagler 1 asterism (RA 6h 23m Dec $-26^\circ 17'$), and I observe and sketch this inverted chevron of stars in Canis Major as seen in the 4.4° field of my binoculars. We all take a nap, and Quinn and I rise at 3:00 a.m. to enjoy some Southern Hemisphere splendours in the lower part of Scorpius. Much to see! Quinn sees a brilliant fireball; I only see the very end and the 20-second trail. The Moon rises at 5:30, just before dawn, and we wait to see Venus before sunrise. The earthshine does not look as bright, but it is hard to be sure. The geometry looks favourable for observing an old Moon about 20 h from new the following day, although the sky looks questionable, as there seems to be a persistent band of haze at the horizon.



Figure 4 — Moonrise, 2013 February 7, with the Milky Way parallel to the horizon. (Canon XSi, ISO 1600, 50-mm $f/1.8$ lens, 15 s, untracked)

Night Five: We have had an unprecedented string of five nights' observing at the WSP. This one is a relaxed night, but we make two remarkable observations: Sirius B, also called "The Pup," and an old Moon, 20 hours from new. A WSP neighbour directed his 406-mm (16-inch) tracking Dob to Sirius (mag. -1.5) at high power, and at the edge of the shimmering diffraction pattern, we spy Sirius B (mag. $+8.5$) at separation $10''$. This is an observation aided by a narrow field of view, and Quinn discovers that he can block out brilliant Sirius by backing his head away from the eyepiece and positioning his eye slightly to one side. I am going to try this at home with my 12-inch Dob. We rise at 5:30 a.m. to prepare for moonrise at 6:14. Quinn and I had made a dry run the previous day, and we had been talking about it before midnight, so a small group joins us to look for the low-altitude crescent, while everyone else is in bed or packing to leave. There are few clouds, but the haze is thick for a couple of degrees at the horizon. Before dawn's light, I measure an SQM reading of 21.5 away from obvious sky glow. Greg slews his GoTo refractor to the Moon's position shortly after moonrise and finds it in the eyepiece. Dave VIII finds the slim crescent at about the same time, sweeping with his Dob at VERY low altitude. Quinn finds it in his ED80 $f/7.5$ refractor, and then uses the red-dot finder to locate the point in the sky to look with the unaided eye. I find it in binoculars but cannot see

it unaided until I use Quinn's method. The time is 6:26, 12 minutes after moonrise, 36 minutes before sunrise, with the Moon at an altitude of just under 3° . After this, we cannot maintain unaided eye contact, as the sky is brightening.

While searching for the Moon, I snapped several exposures with a Canon SXi and 300-mm lens to set the background brightness, and I later discover that I have captured the crescent in the haze on several frames around 6:19 a.m. (Figure 6). Venus rises after the Moon, and for a short time, I see both the Moon and Venus in binos, and then Venus unaided, but never the two together, unaided. This observation is aided by several factors: a low (ocean) horizon, clear (although hazy) skies, a moderately steep ecliptic angle at the sunrise azimuth (due to our southern latitude), the Moon being north of the ecliptic, and the 12° elongation from the Sun (perigee was 2 days previous), not to mention alert, prepared, and experienced observers!

Night Six: It was too much to ask for six nights of uninterrupted viewing! Our last night is slightly spoiled by clouds, but we have to sleep sometime, especially since we are all compelled to clear out by 10 a.m. the next day, and some of us are driving. Many participants have already left! The last night is fairly social, starting with viewing Mercury after sunset, rising higher every night into the Zodiacal Light. I explore



Figure 5 — Orion was splendidly high in the sky all night long. (Canon XSi, ISO 1600, 50-mm f/1.8 lens, 60s, tracked with MusicBox EQ mount)

more WFW in and around Cassiopeia, not in binoculars but with the aid of Greg's refractor and Dave VIII's low-power eyepiece. I have an extra Handbook to give to someone, and I choose the owner of the large Dob through which we had observed The Pup. It turns out he is named Patrick Moore! He is a member of the Raleigh Astronomy Club (NC). Everyone is yawning, so we repair to the chickee for some liquid Vitamin B, chat, and sleep. Everyone sleeps through the night, but Greg rises at 4:30 a.m. for one last observing session. He was supposed to shake us, but he said "everyone was sawring logs" (imagine this with a Maine accent). We all get up to watch the last sunrise and to pack. I can't say I have ever observed six nights in a row!

Day Seven: Following the WSP, the Gang of Four bid each other adieu, Chris and I drive Quinn back to Miami, and she and I explore the Everglades for a couple of days (see flic.kr/s/aHsjE2qz6K). Before flying home from Tampa, we visit some "snowbird" friends and relatives for a few nights. It was wonderful to escape winter for a couple of weeks! (See more astronomy photos at flic.kr/s/aHsjE2JrGA.) *

Dave Chapman is a retired Defence Scientist and a long-time member of the RASC, having served both the Halifax Centre and the Society. He is currently Editor of the Observer's Handbook. He is also the 17th member of the "Royal" Astronomical Society of Daves.



Figure 6 — The old Moon less than 20 hours from new, 2013 February 9, 6:19 EST. (Canon XSi, ISO 1600, 300-mm f/5.6 lens, 4s, untracked)

Armchair Astrophotography: Processing *Hubble* Data

by Lynn Hilborn
(lynnhilborn@yahoo.ca)

Processing *Hubble Space Telescope* (HST) data can be both fun and rewarding and a pastime to occupy cloudy nights. HST records are available publicly, in the Hubble Legacy Archive (HLA), at <http://hla.stsci.edu/>. This archive is a joint project by the Space Telescope Science Institute, the Space Telescope European Coordinating Facility, and the Canadian Astronomy Data Centre. The spacecraft's data can be readily accessed and downloaded by any avid armchair astrophotographer.

One quickly learns, however, that in most cases the whole of the HST's detectors and filters were not used for the acquisition of data conducive to "pretty picture" (RGB) reconstruction. Instead, these data were collected by scientists interested in specific physical activities or object detection. To create normal colour images, we must "mine" the data for imagery that will most closely resemble or can be assembled into RGB wavelengths.

The renowned astrophotographer Dr. Robert Gendler has concluded that the *Hubble* detectors best suited for colour images include the Wide-Field Planetary Camera 2 (WFPC2), the Wide-Field Planetary Camera 3 (WFPC3),

and the Advanced Camera for Surveys (ACS). In addition, the following filters are best suited for colour processing, with spectrum ranging from blue to red: F435W; F439W; F450W; F555W; F606W; F675W; F702W; F791W; and F814W. The value in each filter designation is the central bandpass (nm) of the filter.

The goal is to acquire data sets of the filtered images that best resemble RGB wavelengths. In some cases, only two of the three filtered sets may be available. The "work around" is to average the two available sets of data to create synthetic data for the third channel. Most astrophotographers are familiar with the technique to create a synthetic green channel by blending red and blue channels.

The HLA data are already calibrated. To access the data, you need the program *FITS Liberator*, which is free software available from www.spacetelescope.org/projects/fits_liberator/. The latest *FITS Liberator* is a stand-alone program that no longer requires *Photoshop*. I use the program to do a simple stretch of the data and to establish black-and-white points. The images are then taken into *Photoshop* as 16-bit TIFFs for assembly as an RGB image, allocating the appropriate matching wavelength to its specific RGB channel. I further enhance the data with curves and levels adjustments to the colour channels, make highlight and shadow adjustments using masks, and perform selective sharpening and cleanup on artifacts and noise. A detailed workflow is available at <http://hubblesource.stsci.edu/services/articles/2005-02-10/>



In many cases, it will take resourcefulness and creativity to manipulate the data into a pretty picture. The end results are indeed rewarding and the learning curve is an adventure not to be missed. The Hubble Legacy Archive is a wonderful repository of data for the intrepid armchair astrophotographer. ★

Figure 1 — This image of NGC 602, a young star cluster near the Small Magellanic Cloud, celebrates the results that are possible using the *Hubble* data. The reefs of reddish gas with swept-back shapes testify to the presence of high-energy radiation and shock waves from the cluster stars that have triggered bursts of star formation as they spread outward from the cluster's centre.

Spanish Island Haven Serves as Locale for International Meteor Conference

by Andrew I. Oakes
(copernicus1543@gmail.com)



Figure 1 — Some of the participants of the 31st IMC visit world-class professional telescopes during their conference on La Palma, the Canary Islands. Photo: Ovidiu Vaduvescu of Astro-Travels, La Palma, Spain

Professional and amateur astronomers from around the world gathered in the Canary Islands, 2012 September 20-23 at the *31st International Meteor Conference (IMC)* to exchange their research findings and meteor-search experiences. Some 110 registrants, representing such countries as Belgium, Romania, Denmark, Russia, the United Kingdom, Canada, the United States, Japan, the Czech Republic, Spain, France, the Slovak Republic, and the Netherlands flew to La Palma for the conference. Participants included a contingent of journalists who arrived to cover the scientific conference, held annually in different host countries.

The Canary Islands are located in the Atlantic Ocean to the west of Morocco, approximately 1700 kilometres and a two-hour flight southwest of Madrid. La Palma is one of 8 major islands in the Spanish archipelago—there are 5 other smaller islands—and has a population of approximately 87,000 inhabitants. It is a volcanic island, witnessing its last volcanic activity in 1971.



Figure 2 — A view of the dome of the 10.4-m Gran Telescopio Canarias



Figure 3 — The mirror and supports of the 10-m Gran Telescopio.

The highlight of the conference was a specially organized insider's tour of the world-class astronomical compound featuring a grouping of professional telescopes operated year-round by a consortium of participating countries. The state-of-the-art telescopes at the Observatorio del Roque de los Muchachos lie at 2400 metres above sea level, well above the surrounding clouds, and so, blessed with pristine air quality and cloudless viewing conditions. The complex sits at the edge of the Caldera de Taburiente National Park on some 189 hectares of land on the La Palma Island at latitude 28°45' N, where they have a good view of the southern sky.

The observatory complex rivals those located on mountaintops in Chile and Hawaii.

The multi-observatory compound features 16 instruments, ranging from a robotic camera, SuperWASP, to telescopes named after Jacobus Kapteyn (100 cm), MERCATOR (120 cm), Isaac Newton (250 cm), Galileo (350 cm), William Herschel (420 cm), Gran Telescopio de CANARIAS (1040 cm), and Telescopio Cherenkov MAGIC I and MAGIC II (1700 × 2 cm). There are two solar telescopes—one of 45 cm and the other of 97 cm. Gran Telescopio CANARIAS, the biggest telescope in the world, saw first light in July 2009.



Figure 4 — A typical street scene in the town of Santa Cruz de La Palma, La Palma Island.

“I hope you have a complete idea of La Palma,” said Ana Castañeda, a tourism area technical staff member with Cabildo Insular De La Palma, the local government body that helped fund some of the conference's extracurricular events. “On behalf of the island government I welcome you and wish you a nice stay with us,” she said during an impromptu press scrum.

During the 4-day meteor conference, participants heard 40 lectures and discussed 17 presented posters. Some of the subjects were:

- *Results of the Draconids 2011 observation with the BRAMS network*—Stijn Calders & Cis Verbeek, Belgian Institute for Space Aeronomy, Royal Observatory of Belgium
- *A Meteor Propagation Model Based on Fitting the Differential Equations of Meteor Motion*—Pete Gural, USA
- *Meteorites in Japan*—Nagatoshi Nogami, Japan
- *My successful EURONEAR collaboration with students and amateur astronomers*—Ovidiu Vaduvescu and the EURONEAR team, La Palma, Canary Islands, Spain
- *Is it possible to observe meteoroids ejected from asteroid (3200) Phaethon in 2009?*—G.O. Ryabova, Tomsk State University, Russia
- *Data from several meteor networks in Europe*—L. Kornoš, J. Koukal, R. Piffel, J. Tóth and European viDeo Meteor Observation Network team [France BOAM network / Base des Observateurs Amateurs de Météores; Hungarian Meteor Network / Magyar Hullócsillagok Egyesület; Italian Meteor and TLE network; Polish Fireball Network / Pracownia Komet i Meteorów, PKiM; UK Meteor Observation Network; Central European Meteor Network, Czech and Slovak AA; and Slovak VideoMeteor Network, CU
- *Meteor Shower Flux Densities and the Zenith Exponent*—Sirko Molau, AKM, Germany, and Geert Barentsen, University of Hertfordshire, UK

The 32nd International Meteor Conference is being held this year in Poznań, Poland, from 2013 August 22-25. The IMC planners note that their conference will be closely connected with the 8th Meteoroids 2013 Conference organized a few days later in the same city, the capital of western Poland. The Institute Astronomical Observatory of the Adam Mickiewicz University in Poznań is convening the Meteoroids 2013, 2013 August 26-30. ★

Andrew Oakes attended the IMC conference representing the RASC Journal in his capacity as a Contributing Editor.

Solar Eclipse Crossword

by Naomi Pasachoff

ACROSS

1. Opposite of *nord*, in Nantes
4. Old MacDonald's property
8. Strike a _____
13. Completed
14. Region
15. What one would like right after totality
16. Manchester United defender Patrice
17. Polaroid photography inventor
18. An observer in the _____ experiences a total solar eclipse
19. Solar eclipse phenomenon
22. "_____ through the tulips"
23. Go to the ____ (fight hard)
24. Bikini top
27. Stellar explosions (abbr.)
28. Shoshonean tribespeople
31. Annular/total eclipse
33. Prime Minister after Churchill
35. Voided plays
36. Device for observing partial phases
40. Source of wisdom
41. Compressed-air-powered prototype vehicle
42. Part of eclipse when first contact occurs
45. _____ the corner
46. Flying mammal
49. *Sky & Telescope* supports _____-am collaboration
50. What one does after a clouded-out eclipse
52. Like 8, 23, and 45 across
54. Part of Sun visible to the naked eye only during totality
57. Wife of Nobel Prize physicist Enrico Fermi
61. Midnight snack at a telescope
62. Asteroid type
63. Part of VLA
64. Orion nebula observers note its greenish _____
65. New Jersey basketball team
66. Eclipse phenomenon shadow _____
67. College Board exams
68. *Science Friday* host Flatow

DOWN

1. Carly Simon's "You're _____" refers to 1972 Nova Scotia eclipse
2. Immature
3. Distributed the cards
4. Frankie Valli or Eddie Kendricks, e.g.
5. Tidal river Shatt-al-_____
6. Astronomers Ong or Walterbos
7. First word of famous palindrome
8. Like a good bread roll
9. Something to raise

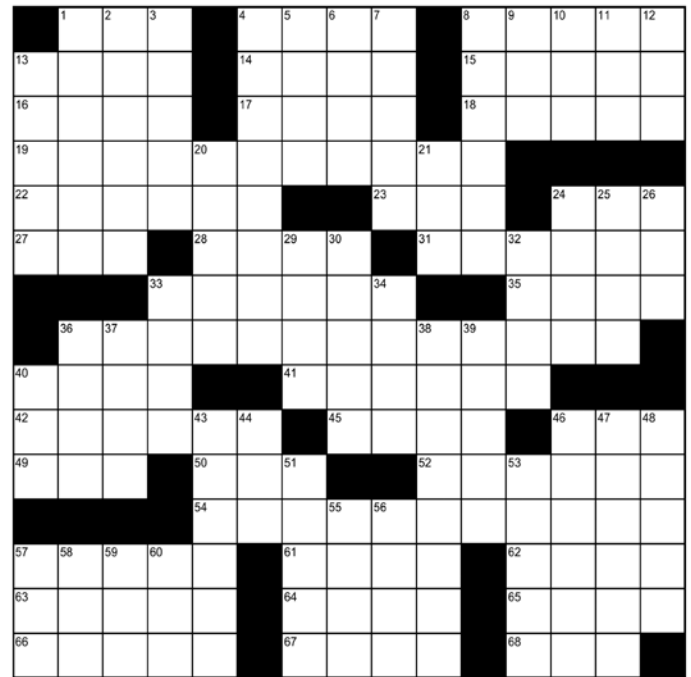

10. Celestial sphere
11. Play about robots' revolt
12. Watson and Crick discovered its structure
13. "Forgive us our _____"
20. Between childhood and adulthood
21. Morse Code syllable
24. *Uncle Remus* characters Fox or Rabbit
25. New Mexico State University astronomer Beebe
26. Don Draper products
29. "First Lady of Song" Fitzgerald
30. "Now you _____, now you don't"
32. Drew sap from a tree
33. Formicary inhabitants
34. Bridal colour
36. Serve milk or juice
37. Sondheim's _____ *the Woods*
38. Fragile relatives of prunes
39. Original "shockumentary" _____ *Cane*
40. Coxcomb or dandy
43. Non-multiple-choice questions on 67 across
44. Overly
46. Postwar baby-_____ generation
47. Lil Wayne album *I _____ Human Being*
48. Romanovs, e.g.
51. Things to keep off one's escutcheon
53. Persian
55. Song for Deborah Voigt
56. Jonathan Larson's magnum opus
57. With 60 down, a Lawrence Berkeley or MIT facility
58. Southern constellation
59. Large vase
60. See 57 down

Answers will appear in the August issue of the *Journal*.

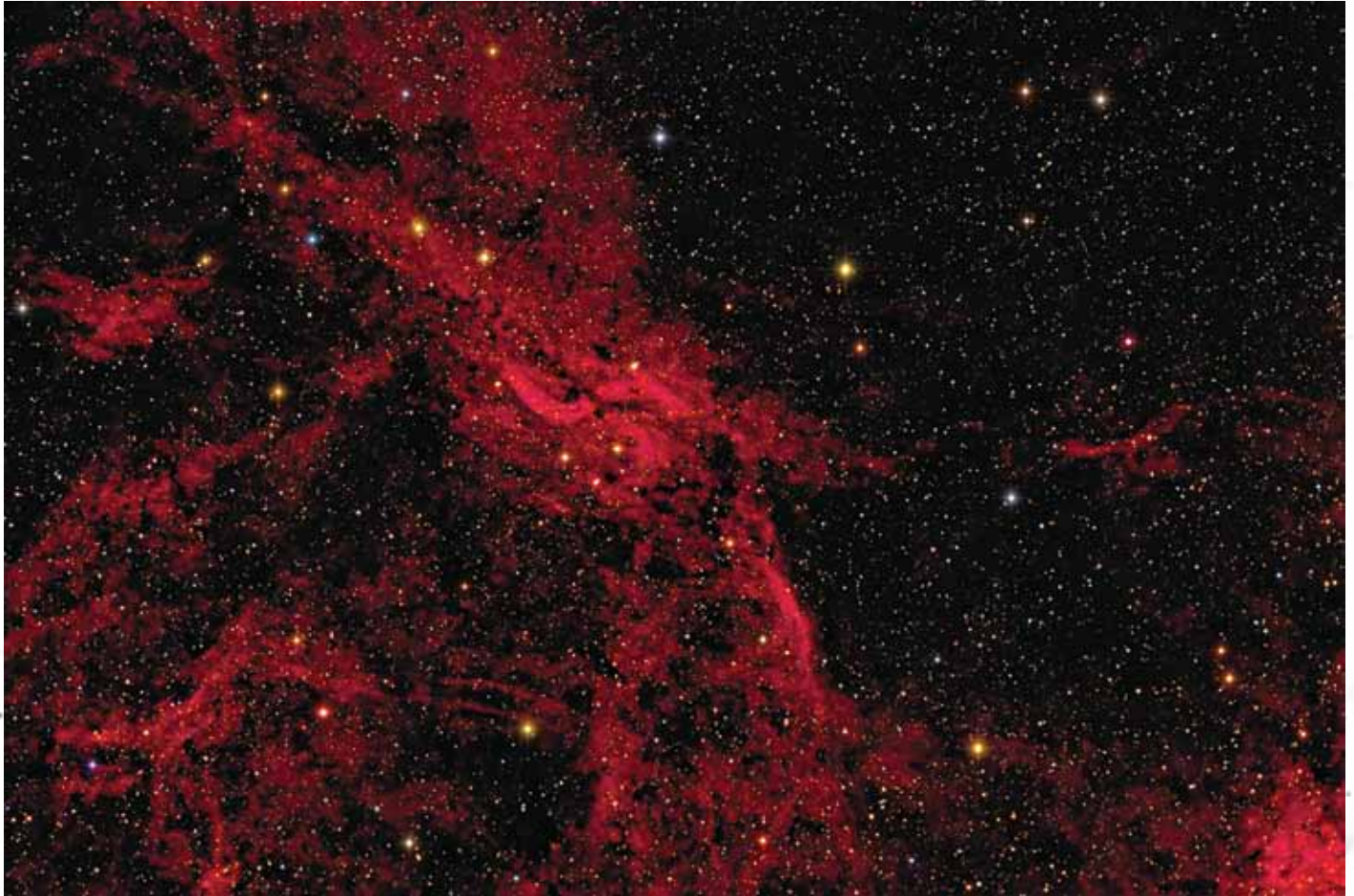

Figure 1 — This mottled and mostly red image is the Propeller Nebula (Simeis 57) and its surroundings, provided by Joel Parkes. The image is composed from 4.5 hours of H α and 25 minutes each of R, G, and B colours. The Propeller Nebula lies in Cygnus but otherwise is relatively unstudied. It has a low mass—only 10s of solar masses—and is partly blocked by intervening dust.

Figure 2 — Stan Runge of the Winnipeg Centre caught Comet PanSTARRS in the late evening using a 6-inch f/5 Newtonian on March 25. This image is a combination of 10 sub-images, each of 10 seconds exposure using a Canon T1i. In spite of its brightness, PanSTARRS proved to be a difficult comet to find visually because of its low altitude in the twilight.





Figure 3 — Blair MacDonald is still working on this image of M81, but has offered to share it with *Journal* readers after 144 minutes (72×2 m) of exposure. Blair is using a Canon 60Da and ISO 1600 at the prime focus of a 200-mm SkyWatcher *f*/5 Newtonian reflector and a TeleVue Paracorr for a total focal length of 1150 mm. The photons were caught in urban skies at Bedford, N.S.



Figure 4 — Dalton Wilson provides us with this image of the Orion-Monoceros region, including Barnard's loop, the Orion Nebula, the Horsehead Nebula, Sharpless 264, and the Rosette Nebula. Dalton set up in the dark skies of the Painted Pony Resort at Rodeo, New Mexico, using a QSI540WS camera with a Nikkor 28-mm lens. Exposures were 8×300s in each of R, G, and B, and 14×600s exposures in H α .

Lennox & Addington County: A Dark-Sky Treasure in Eastern Ontario

by Rob Plumley, County of Lennox & Addington
(rplumley@lennox-addington.on.ca)

It's becoming increasingly more difficult for both enthusiastic amateur astronomers and casual stargazers alike to get a clear view of the night sky in the ever-urbanizing geography of southern Ontario.

But there is still one refuge close to the heavily-populated Highway 401 corridor across the province that has retained wonderfully vibrant starscapes without the intrusion of ambient light from urban centres: the Dark-Sky Viewing Area in Lennox & Addington County.

Located north of Napanee near the village of Erinsville and the Sheffield Conservation Area in Stone Mills Township, the Dark-Sky Viewing Area can be accessed off County Road 41 by either Highway 401 from the south or Highway 7 from the north. It is about 45 minutes from either Kingston or Belleville, and a little over two hours from Ottawa and Toronto. The location allows astronomers to experience the most southerly dark skies anywhere in southern Ontario and basically replicates what the night sky would have been like more than a century ago.

The site features a large, flat concrete pad for both camera tripods and telescopes and plenty of room for portable chairs, meaning even folks who just want to gaze up at the stars without telescopic aid can enjoy the pristine brilliance of the night sky. A parking area is just steps away. Under the guidance of Canada's well-known professional astronomy writer, Terence Dickinson, L&A County created the infrastructure necessary to allow observers to pursue their astronomy interest.

"I have photographed the night sky from some of the most favourable locations in North America, and there are parts of the northern two-thirds of L&A County where viewing conditions rank among the best. The Milky Way is brilliant, and the light pollution from distant cities is virtually non-existent," Dickinson said in a newspaper article back in 2010.

And in another interview, Dickinson pointed out that a dark night sky almost entirely free of light pollution, yet easily accessible via a first-class highway, is becoming a rare commodity in North America. He said that at present, 80 percent of Canada's population never see the sky as folks coming to the L&A County Dark-Sky Viewing Area do, without having to travel a substantial distance.

Besides countless accolades from visiting astronomers from across North America and beyond, the L&A Dark-Sky

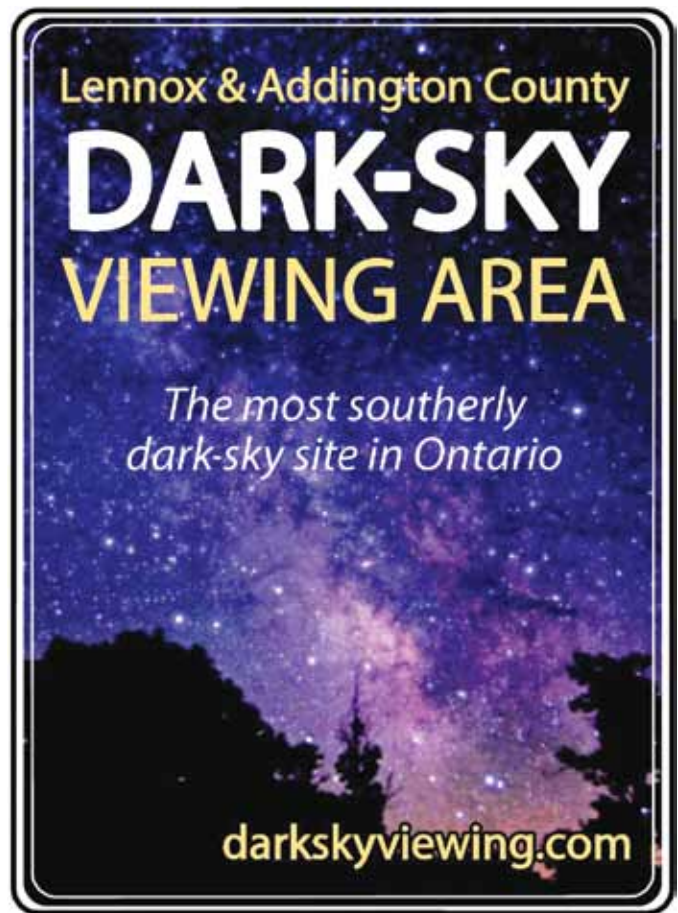

Viewing Area earned L&A County a 2012 provincial marketing award from the Economic Developers Council of Ontario.

L&A County Economic Development Manager Stephen Paul understood the tourism possibilities for having such a rare natural resource in the middle of the county, and has leveraged it as a way of bringing in visitors, many of whom will come for a few days and stay in local hotels, shop at local stores, and eat at local restaurants.

"All you need to do is look at a light-pollution map of North America, Ontario specifically, and you will see a big dark area in the northern part of Lennox & Addington, and that's a great opportunity for us," said Paul in a press interview, who added that the ongoing input and practical assistance from Dickinson has been huge in the development of the Dark-Sky Viewing Area and the notoriety of L&A County as a great place for astronomy.

The L&A County Dark-Sky Viewing Area is open every night of the year. Several guided constellation tours and public telescope viewing sessions are being planned for 2013, weather permitting.

For more information, visit www.DarkSkyViewing.com. ★

Cosmic Contemplations

Music of the Spheres

by Jim Chung, Toronto Centre
(jim_chung@sunshine.net)



Having experienced one of the most uncooperatively cloudy winters to date, my current slate of astronomically themed projects has been relegated to development limbo. However, I cannot resist revealing that future columns will be devoted to the

construction of: an 8.5-inch (216 mm) *f*/12 folded achromatic refractor; a double-stacked image-intensifier eyepiece; and an atmospheric dispersion corrector. This month, you, gentle reader, will have to remain satisfied with a discussion of music and astronomy.

On the face of it, there doesn't appear to be any commonality between music and astronomy, and that's the way I also perceived it while listening to the local classical-music radio station in my car during an emergency food run. The program host's (highbrow stations like public radio and jazz don't employ DJs) velvet baritone *segue* went something like this:

...and that was the first movement of Symphony Number Eight, the Allegro Assai, by William Herschel. Herschel is better known as the Father of Modern Astronomy because it was on this day in 1781 that he discovered the planet Uranus. Can you imagine the conversation around the watercooler at his next rehearsal?

I was astounded, as I had never known that Herschel was a musician, let alone such an accomplished one.

Herschel was born (1738) in Hanover, Germany, as the second son to a family of ten children, of which only six survived to adulthood. His father was an oboist in the Hanover Military Band attached to the Hanoverian Footguards Regiment, and both William and his brother Jacob joined him in like fashion as they came of age. King George II of England was a member of the royal German dynasty that controlled Hanover. During the Seven Years' War between England and France, the Herschel men saw combat and defeat (1757), and the father convinced his two sons to desert and seek their fortunes in England.

William also played the cello, violin, piano, harpsichord, and organ, and was a skilled craftsman able to fabricate his own instruments, a versatility characteristic of professional journeyman musicians of his period. He found early employment as a sheet-music copyist in London. Later he was appointed the director of the Durham Militia Band and, undismayed by a complement that consisted of merely two oboes and two French horns, he composed martial music

that played to their strengths. He became first violinist for the Newcastle Orchestra and then organist at St. John the Baptist Church in Leeds & Halifax before achieving premier recognition in 1767 as the organist of Octagon Chapel in Bath with the princely annual salary of £400. He was promoted to director of the Bath Orchestra in 1770. This decade also proved to be his most productive, as he composed 24 symphonies and several concertos for oboe, violin, and keyboard. His music may not have the enduring calibre of his contemporaries Handel, Haydn, and Mozart, but to the ear of this most mediocre (but once professional) musician, they speak of the innovation and creativity of Herschel's well-ordered and complex mind. His music is not derivative or forgettable; I found it pleasing to listen to, and I enjoyed its carefully crafted structure.

Herschel rescued his sister Caroline from a life of domestic servitude in Hanover (1772) to become a soprano soloist, while his brothers Dietrich, Alexander, and Jacob also became members of the orchestra.

Despite the burdens and demands of becoming the family patriarch, he found time for the selfish pleasure of reading scientific texts in bed, including Robert Smith's *Harmonics* and *A Compleat System of Optiks* and James Ferguson's *Astronomy*. In 1771, he began construction of a series of Newtonian reflectors, often spending up to 16 hours a day grinding a speculum mirror, while his sister spoon-fed him his meals. He became so taken with astronomical observation that he was forced to reduce the number of his musical pupils, and his last professional music appearance was in 1782. By this time, he had gained recognition for the discovery of Uranus by the award of the Copley medal, membership in the Royal Society, and appointment by King George III as *King's Astronomer* with a lifetime royal stipend of £200 annually. Giving up music was apparently not difficult, as Herschel writes:

All this while I continued my astronomical observations & nothing seemed now wanting to compleat my felicity than sufficient time to enjoy my telescopes to which I was so much attached that I used frequently to run from the Harpsichord at the Theatre to look at the stars during the time of an act & return to the next Music.

And when the King later commissioned Herschel to build the world's largest telescope, a 48-inch (1.2-m) reflector, novelist Frances Burney writes:

The King has not a happier subject than this man ... who is indulged in license from the King to make a telescope according to his new ideas and discoveries, that is to have no cost spared in its construction and is wholly to be paid for by His Majesty. This seems to have made him happier even than the pension, as it enables him to put in execution all his wonderful projects, from which his expectations of future discoveries are so sanguine as to make his present existence a state of almost perfect enjoyment.

I've come to realize that Herschel is no anomaly, as we have two contemporary musicians who have achieved critical and financial success before progressing to a second career in astronomy.

Brian May received his Bachelor of Science degree in physics from Imperial College and began working as an astronomer studying the radial velocities in the zodiacal dust cloud using optical spectrometry. He was also lead guitarist in a local band fronted by childhood chum and neighbour Farrokh Bulsara, aka Freddy Mercury. When the band *Queen* hit the big time in the early 1970s, May had to give up astronomy, and more than 30 years would pass before he was able to resume his research and receive his doctorate in 2007. And, like Herschel, throughout his five-decade musical career, he played the same electric guitar (*Red Special*) that both his father and he spent 18 months making when he was 15 years old.

Closer to home, our own Wayne Parker was bassist for a band called *Glass Tiger* that caught the public eye in 1984. He maintained his passion for astronomy by touring with a Tele Vue Genesis refractor for the next decade. When life resumed, and he was getting too busy with his own software distribution company to easily enjoy astronomy, he decided he had to find a way back. In 2003, he launched SkyShed, which offered optimized designs for roll-off roof observing sheds, followed with Skyshed POD in 2006.

The origins of a relationship between music and astronomy began with the ancient Greeks. Pythagoras observed that the pitch of a musical note generated from a vibrating string depends upon its length, and that if you halve the length of the string, you produce the same note but pitched one octave higher, and that this interval could be expressed as a 1:2 ratio. He was obsessed with the notion that the Universe could be defined within the constraints of small integers and was delighted to discover that consonant or harmonious sounding intervals such as a perfect fifth (five whole tones above the tonic, e.g. C-G) are exactly 2:3 and a perfect fourth can be made from a 3:4 ratio. By expressing harmony mathematically, he was the first to reduce a quality (sound) into a quantity, thereby opening the doors to the concept that the Universe itself could be described mathematically.

Since objects produce sound when in motion, he reasoned that the planets moving in orbit should also produce a sound, and that this sound is harmonious, since the separation ratios of the planets as a distance proportional to their speed relative

to the Earth also seemed to correspond to the tonal musical intervals of the Pythagorean scale. This *music of the spheres* was what Kepler also looked for when proposing his laws of planetary motion, and he found that the ratio of each planet's angular velocity at perihelion and aphelion was identical to one of the established musical interval ratios. Saturn had a ratio of 4:5, which corresponds to a major third, while Jupiter at 5:6 is a minor third.

As it turns out, constructing scales based on pure ratios of small integers results in some intervals that are horribly dissonant, and as music became more complex through the Middle Ages, with more polyphony and key changes, these bad intervals became more common. The modern 12-tone even-tempered scale was invented to solve this problem, whereby the octave is divided into 12 exactly equal intervals, so that interval ratios are within 1 percent of the perfect system envisioned by Pythagoras. Vincenzo Galilei (the father) was an early advocate of this system, and this seeming rejection of a pure abstract mathematical model of the world was the path his son Galileo and the rest of us would later follow. It took an even later Italian by the name of Gabriele Veneziano in 1968 to revisit the Pythagorean construct and propose that matter, force, even space and time are composed of tiny vibrating strings instead of a point particle. String theory remains the best candidate to unify the incongruous theories of quantum mechanics and general relativity.

So what it comes down to is that music has very little to do with math and even less to do with astronomy. I also believe that playing Mozart to your unborn fetus will do nothing to raise its intelligence. Learning music and the ability to sight-read a musical score may raise math scores, because both involve quick pattern-recognition and decoding skills. That three prominent musicians found careers in astronomy has more to do with astronomy as an infant science, even in the 21st century. I am grateful that amateur astronomers continue to make meaningful contributions to the real science of astronomy, because it allows me the most tenuous of footholds in academia, a world that so many of us leave in order to chase the North American dream. ★

Jim Chung has degrees in biochemistry and dentistry and has developed a particular interest for astrophotography over the past four years. He is also an avid rider and restorer of vintage motorcycles, which conveniently parlayed into ATM (amateur telescope maker) projects. His dream is to spend a month imaging in New Mexico away from the demands of work and family.

RASC members receiving this *Journal* in electronic format are hereby granted permission to make a single paper copy for their personal use.

Imager's Corner

The Noise about Noise

by Blair MacDonald, Halifax Centre
(b.macdonald@ns.sympatico.ca)

WARNING: This edition of Imager's Corner will be a little more technical than usual, but after scanning emails from new astrophotographers in several Centres, I have found that few topics in astrophotography cause as much confusion as noise and proper exposure. In this column, I will attempt to present some of the theory that goes into determining the "correct" exposure for a given scene and then show some simple guidelines that can make it easy—at least for DSLR users. As someone who works with a variety of signal-processing systems in my day job, I've become well acquainted with noise and its properties. Noise, by its random nature, can be confusing, but with a little knowledge, we can quiet most of the *noise* about noise and take steps to control its effects in our images. The whole idea is to figure out the proper exposure to reduce noise as much as possible and produce good quality data ready for processing.

What is Noise?

First, let's get a working definition of noise as it relates to imaging. Officially, noise is any artifact in an image that is not present in the actual scene. This seems to be a little bit too broad a definition, as it encompasses optical defects, which we leave for other treatments. Instead, we can define noise as "a random image artifact that is a function of a component in the data-acquisition system or a function of the scene itself." In this case, the former means the camera excluding the optical system (scope or lens), and the latter means photon noise. As we will see, the random nature of noise is very important in combatting its effects.

Types of Noise Encountered in Astrophotography

There are generally two noise sources we are concerned about in astrophotography: photon (image noise) and camera noise.

Collectively, the culprits in camera noise are dark-current noise, quantization noise, and read noise. Dark-current noise is the one with which we are most familiar: it is the signal that builds up in the sensor even without any light falling on the chip. This noise is proportional to both the exposure time and the temperature. Dark-current noise can be modelled as a combination of a fixed, deterministic value that is dependent on temperature and exposure time, and a random variation about this fixed value that has a zero mean value when averaged. In fact, it is because part of the dark signal is

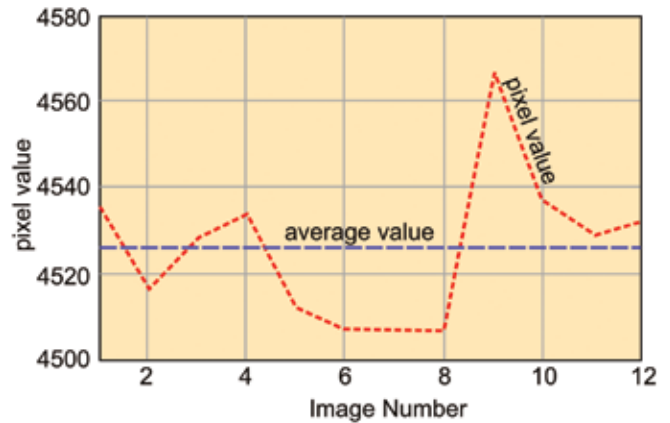

Figure 1 — The value of a single dark-current pixel over several images of similar exposure. The dark current is made up of a fixed value (average) and a random "pixel value" component that averages to zero.

constant that we can remove it with a dark frame. If we look at just one pixel in a dark frame and plot its values over many dark-frame images, we get a graph that looks like the one shown in Figure 1.

In Figure 1, we see that the collection of pixels has an average value (blue dashed line) of 4526 counts, around which individual pixels vary with a random fluctuation. If we produce a similar plot for every pixel in the dark frame, we would find that each one has its own average value. A well-averaged dark frame is an image made up of these constant values. Subtracting a dark frame removes the average dark signal from the image, producing a much less noisy picture. What remains is the actual image data plus the random variation in the dark signal collected during the exposure time. It is this random fluctuation that makes up the remaining dark-current noise and it can be thought of as a zero-mean random signal. This remaining noise is proportional to the square root of the integrated dark current; it scales with temperature, such that it doubles roughly every seven degrees.

Readout noise is caused by noise in the analogue amplifier chain between the sensor and the analogue-to-digital converter or ADC. This noise has a fixed level and, unlike dark-current noise, is not proportional to exposure time. Quantization noise results from the fact that the ADC outputs only discrete integer values. If the actual signal falls between possible ADC values, a small error (noise) results.

For purposes of this discussion we will ignore the effects of quantization noise, as it is small compared to the others in modern cameras with 12 to 16 bit ADCs. Instead we will consider only read and dark-current noise.

The remaining non-instrumental source of noise comes from the image itself. Quantum mechanics tells us that light itself is noisy; photon noise is inherent in electromagnetic radiation and has a Poisson distribution with an average value equal to the square root of the number of photons collected at each pixel.

The SNR Equation

There is a classic equation describing the signal-to-noise ratio (SNR) of the data collected at each pixel in a digital camera:

$$\text{SNR} = \sqrt{n} \frac{s_{\text{obj}} t}{\sqrt{s_{\text{obj}} t + s_{\text{sky}} t + s_{\text{dark}} + n_{\text{read}}^2}} \quad (1)$$

Where:

- n = number of sub-exposures and assumes an “average combine” in the final image.
- s_{obj} = object flux in electrons per unit time
- s_{sky} = sky background flux in electrons per unit time
- t = exposure time in units matching the units used for s_{sky} and s_{obj}
- s_{dark} = number of dark-current electrons
- n_{read} = readout noise in electrons

From this, we can readily see that the SNR improves with the square root of the number of sub-exposures. With a little more inspection, we can also see that it improves with the square root of the exposure time. Now comes the interesting part. From the definition of SNR we have:

$$\text{SNR} = \frac{\text{signal}}{\text{noise}}$$

and the pixel SNR equation then tells us that the signal is $s_{\text{obj}} t$ and the noise is

$$\sqrt{s_{\text{obj}} t + s_{\text{sky}} t + s_{\text{dark}} + n_{\text{read}}^2} \quad (2)$$

The expression for the noise breaks down into two terms: image noise made up of $s_{\text{obj}} t$ and $s_{\text{sky}} t$ plus camera noise made up of s_{dark} and n_{read}^2 . Now if the image noise is much larger than the camera noise, we can ignore the effects of camera noise and the pixel SNR simply becomes:

$$\text{SNR} = \sqrt{n} \frac{s_{\text{obj}} t}{\sqrt{s_{\text{obj}} t + s_{\text{sky}} t}} \quad (3)$$

This tells us that if we can make the image noise much larger than the camera noise, then using n exposures of t seconds is identical to a single exposure of $n \times t$ seconds, assuming the short exposures are averaged. This conclusion is of great

interest in astrophotography, because it is much easier to take multiple short exposures than a single long one. If something goes wrong, you lose a single short exposure rather than the whole thing! This all boils down to one question—how do we insure that the image noise is much greater than the camera noise?

The Noise Myth

The first thing we need to understand is that it is not necessary to keep noise to low values in our data. The absolute level of the noise, provided it does not cause saturation of the electronics or the image file format, is meaningless. It is only the ratio of the image signal to the noise (the SNR) that matters; everything else can be scaled and manipulated in your image processor. To demonstrate this point, take a look at Figure 2, which shows two simulated star images that were generated using mathematical modelling software.

The image on the left actually has a higher noise level than the image on the right, but because it has a higher SNR, it looks much better. Both images have been stretched in the same fashion to make the noise obvious.

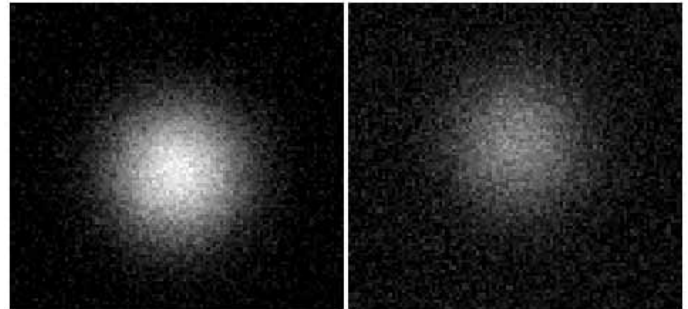

Figure 2 — A simulated star image showing its appearance at differing SNRs.

Determining the “Correct” Exposure

How do we determine the correct exposure for a given image?

First off, I’d like to point out that there is no one correct exposure. Like all photography, it depends on what part of the scene you are trying to capture. Many objects have a wide range in brightness, and you may want to choose a short exposure to better capture detail in the bright areas. The definition I’m using here is to give the best SNR over the whole of the image, even if it allows the brightest parts of the scene to saturate.

Our goal is to determine what sub-exposure will allow the image noise to dominate the camera noise so that we can safely ignore the effects of camera-generated noise. This is the very definition of a sky-limited exposure.

The first step in this exercise is to see how camera noise and image noise combine. There is a branch of mathematics (if you

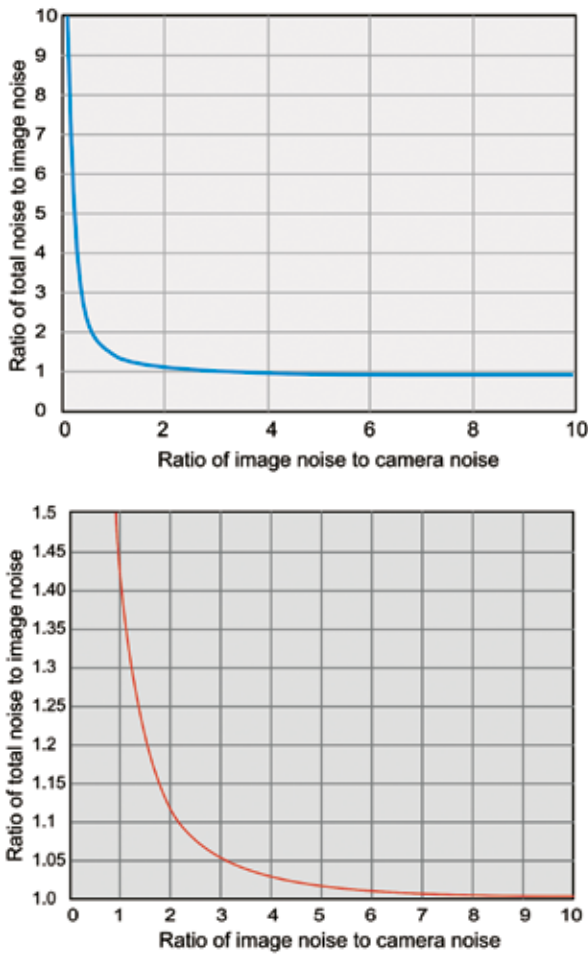

Figure 3 — Total-noise ratio versus image-noise ratio. The bottom image is a magnified view of around the inflection point of the top curve.

think of statistics as mathematics) that shows us that the average value of the summation of two or more random sequences is equal to the square root of the sums of the squares of the average value of the individual sequence. Using this relationship, we can examine how the total noise varies as the ratio between the image noise and camera noise changes. If we plot the ratio of total noise to image or sky noise against the ratio of image noise to camera noise, we get the plots shown in Figure 3.

As you can see from the top graph, shortly after the image noise increases to twice the value of the camera noise, then for all intents and purposes the total noise is simply the image noise. If we zoom in on the area of the plot around the inflection point (bottom graph), we can see things in better detail.

An image is generally accepted as sky-limited if the total noise increases by no more than five percent due to the addition of camera noise. In the right-hand graph of Figure 3, you can see that this occurs when the sky or image noise is approximately three times the camera noise. If we are averaging sub-exposures, then exposing each sub beyond this limit is of little value as seen from the pixel SNR equation. So now we have a working

definition of a sky-limited exposure: expose each sub until the sky noise is three times the camera noise.

Now the problem becomes one of determining just how long an interval this is. To do this, we have to revisit the pixel SNR equation and make a couple of assumptions. Firstly we must assume that all the sub-exposures have been properly calibrated using a well-averaged dark frame. Secondly we assume that the sky signal is greater than the object flux, the case in most astrophotography. This means that the contribution of dark current to noise is greatly reduced and the SNR equation simplifies to

$$\text{SNR} = \sqrt{n} \frac{s_{\text{obj}} t}{\sqrt{s_{\text{sky}} t + n_{\text{read}}^2}} \quad (4)$$

Here the background noise depends only on the sky level, assuming that it overwhelms the camera read noise.

Now we need to be able to measure the sky level and to do this, you need to know the system gain of your camera in terms of electrons per ADU (analogue-to-digital converter units). You can find this in your camera manual, on the Web, or you can measure it directly. Once you know this value, you can use a test exposure to measure the sky background. Take a short exposure, in which the sky is well below saturation, but where the image histogram is completely separated from the left side of the plot. The number of electrons captured is calculated using:

$$s_{\text{sky}} = \frac{\text{gain ADU}}{t_{\text{exposure}}} \quad (5)$$

where s_{sky} is the sky flux and t_{exposure} is the exposure time. The goal here is to make the sky noise three times the camera noise, so knowing the sky flux and the fact that noise adds as the square root of the sums of the squares, we just need to find the camera read noise and we can calculate the required exposure time. The read noise, like the gain, can be obtained from your camera manual, the Web, or it can be measured. Once these are known, the exposure time can be calculated from:

$$3n_{\text{read}} = \sqrt{s_{\text{sky}} t} \quad (6)$$

After which, solving for t , we obtain:

$$t = \frac{9n_{\text{read}}^2}{s_{\text{sky}}} \quad (7)$$

This is the exposure time required to make the image noise of the sky background equal to three times the camera read noise. This method gives us an accurate exposure time, but it is a bit of a pain to do each time you go imaging. It turns out that

there is a short cut that uses the above method for calibration. Use the above method to determine the sky-limited exposure, then take an exposure using the calculated time. Examine the histogram of this sky-limited exposure and note where the peak of the histogram is located.

The next time you want to know the sky-limited exposure time for any given conditions, take a test exposure and note where the peak of the histogram is located. Then simply figure out how much more or less exposure time is needed to move it to the position found above to obtain a sky-limited exposure. I've calibrated three Canon DSLRs using this technique and in each one, the sky-limited position of the histogram was one quarter of the way from the left hand side of the histogram plot.

Let's take a look at an example using my Canon 60Da. Suppose a test exposure of two minutes produces a histogram with a peak at the one-eighth point. Since CCD and CMOS sensors have a linear response with integration time, the exposure should be increased to four minutes to produce a sky-limited sub-exposure. That's all it takes; a calibration session to know where to place the histogram peak and a simple test exposure when you go imaging.

How Many Sub-exposures?

Now let's go back to the pixel SNR equation in (1). We notice that the final-image SNR scales with the square root of the number of sub-exposures. This means that each time the number of subs is doubled, the SNR increases by a factor of 1.414, as shown in Figures 4 and 5.

As you can see from the images in Figures 4 and 5, the SNR improves each time the number of subs is doubled, but visually the improvement from 8 to 16 images is less apparent than between 1 and 2. Even though the SNR has improved by the square root of two at each doubling, the noise becomes smaller compared to the signal as the number of images is increased, and so the eye begins to lose the ability to distinguish the difference. We can determine how the SNR improves as the number of subs increases mathematically, but this doesn't really tell us much, as it does not take into account the way the human eye perceives changing SNR.

What you consider as a sufficient number of subs depends heavily on the imaging conditions and your setup. If, like me, you have to lug your equipment to a dark-sky site, then an hour or two of imaging is usually all you can achieve in one session. If you have a more permanent installation, then spending many hours on a target is not out of the question. There is a law of diminishing returns at work here; if you have collected three hours of data, then six hours will offer only marginal improvement. If after three hours, you are almost happy with the result, then perhaps a little more noise reduction is better than another three hours of exposure.

Sometimes, especially if your imaging time is limited and you want to get several targets, it is nice to have a rough idea of how many subs are required to get a decent image. You can calculate everything you need with the help of a little integration, but I prefer to simply get a rough calibration for my optical and camera systems and use those to calculate the number of subs required.

The goal is to measure the sky brightness, calculate the target brightness, and then use the SNR equation to determine the required number of sky-limited sub-exposures to achieve the desired SNR.

First, calibrate your system. This can be done anytime and does not need to be repeated each imaging session. The calibration process will relate surface brightness and integration time to ADU values in your camera. We start by taking a sky-limited test image and measuring the average level of the



Figure 4 — A visual comparison the noise characteristics of successively longer exposures of the Horsehead Nebula. Top left: a single 5-minute exposure; top right: two 5-minute exposures; bottom left: four 5-minute exposures; bottom right: eight 5-minute exposures.



Figure 5 — The Horsehead Nebula, composed of 16 5-minute exposures.

with your image-processing software. Determine an average value from a few places on the scene to get a more accurate result. Divide the ADU value for the background of the image by the integration time in seconds. This gives us a value of ADU per second for the energy being received by your camera through your optics. Next we have to measure the sky-background brightness. You can use a sky-quality meter (SQM) or simply use your test image and the technique developed by Samir Kharusi at www.pbase.com/samirkharusi/image/37608572.

Convert the result from magnitudes, which is a log scale, to a linear value by using the equation:

$$\text{linear brightness} = 10^{\frac{\text{magnitude}}{-2.5}} \quad (8)$$

Finally divide the ADU-per-second value obtained in the previous step by the linear sky brightness just measured to obtain a calibration value.

When planning your imaging session, find the integrated magnitude of your target and its size in square arcseconds. Convert the brightness to its linear value and divide by the size to get the surface brightness of the target. Then multiply the result by the calibration value you have obtained for your system. This now tells you the number of ADUs per second you can expect from the target through your optical system. When you get ready to image, use an SQM or Samir's technique to measure the sky background. Convert the sky background to a linear value using (8) and multiply by the calibration constant; then plug the calibrated object brightness and sky brightness into the SNR equation,

$$\text{SNR} = \sqrt{n} \frac{s_{\text{obj}} t}{\sqrt{s_{\text{obj}} t + s_{\text{sky}} t}}$$

to calculate the sub-exposure SNR with n set to one. The last step is to figure out the number of subs required.

Generally a SNR of 36 to 40 is required for a smooth image that can take an aggressive stretch without breaking down into a blurry, noisy mess. The Horsehead shot shown in Figure 5 had an SNR of 36 when all 16 subs were averaged and before any stretching. I'll suggest that 36 is an acceptable SNR value. Using this we estimate the number of sky-limited subs required to be:

$$\left(36 / \text{sub SNR}\right)^2 \quad (9)$$

Now all this may seem like a lot of work, but keep in mind that it is very easy to put the math in a spreadsheet that can be run in something like *Documents to Go* on a smart phone. All that is required is to fill in the object magnitude and its surface area and take a quick measurement of the brightness of the night sky. Plug those values into the spreadsheet and presto, you have an estimate of the number of subs and how long each one has to be for a low-noise image. I've tested this technique on several of my older images, and it agrees with the measured SNR of the stacked images to within a few percent. ★

Remember, this column will be based on your questions so keep them coming. You can send them to the list at hfxrasc@lists.rasc.ca or you can send them directly to me at b.macdonald@ns.sympatico.ca. Please put "IC" as the first two letters in the topic so my email filters will sort the questions.

Blair MacDonald is an electrical technologist running a research group at an Atlantic Canadian company specializing in digital signal processing and electrical design. He's been an RASC member for 20 years, and has been interested in astrophotography and image processing for about 15 years.



RASC Internet Resources

 Like us on facebook

 Follow us on Twitter @rasc

www.rasc.ca
Visit the RASC Web site

www.rasc.ca/discussion
Email Discussion Groups

www.rasc.ca/contact
Contact the National Office

www.rasc.ca/rascnews
RASCeNews

On Another Wavelength

Lunar Swirls



by David Garner, Kitchener-Waterloo Centre
(jusloe1@wightman.ca)

Lunar observers often wonder about the bright young-looking curls found across the lunar surface (Figure 1) that twist and turn across large stretches and appear as a whitish dust covering the darker surface of craters, lunar maria, and highlands. These swirls are no more than surficial features, not a thick layer of material overlaying the surrounding terrain, but they catch the eye and the imagination. One of the best-known swirls, Reiner Gamma, can be seen through a small telescope, lying near the western edge of Oceanus Procellarum, close to the crater Reiner. The central area is a bright ellipse with a long streak running northward (Figure 2).

It is believed that the steady stream of charged particles in the solar wind impacting the Moon over many millions of years causes the larger part of the pale lunar regolith to darken. If this is true, then how is it that these swirls have remained bright?

In order to understand the swirls, NASA had *Apollo* missions 15 and 16 deploy two sub-satellites to fly 100 kilometres above the lunar surface with sensors that measured magnetic fields sprouting up from the Moon's surface. The Moon does not have a global magnetic field, just localized magnetic patches. The swirls are always found associated with magnetic anomalies.

An interesting dust-transport idea invokes the terminator as it moves across the surface of the Moon. The passing terminator causes an electrostatic movement of fine dust, lifting it above the surface. The dust-transport model suggests that a weak electric field resulting from interaction between the solar wind and the magnetic irregularity causes the electrically charged dust to settle in the vicinity of the anomaly and form the swirls.

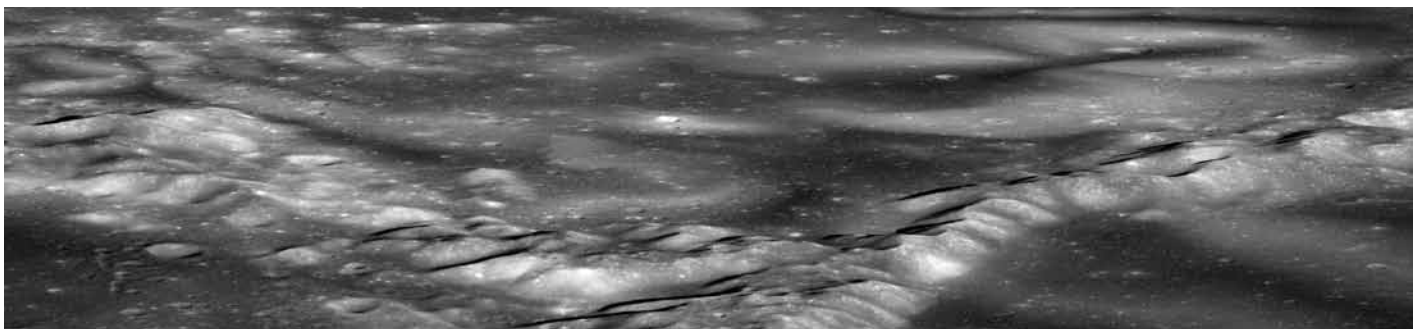

Figure 1 — A wide-angle view of lunar swirls in Mare Ingenii. The rims of Thompson and Thompson M craters are seen in the foreground. View is from east to west, scene is approximately 58 km across [NASA/GSFC/Arizona State University].

Although there are several ideas for this, none have been able to explain the cause of the magnetic anomalies. One conjecture proposes that deposits of strongly magnetized basin ejecta created the irregularity and the swirls; another proposes impact-induced currents and seismic waves around the Moon. It may be a long time before a satisfactory explanation is found.

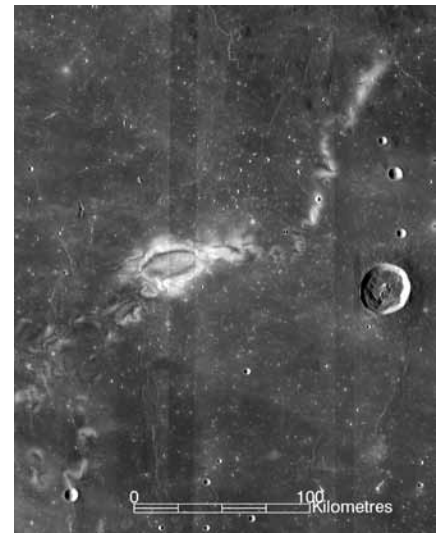

Figure 2 — Reiner Gamma swirls.
Image Credit: NASA/Lunar Reconnaissance
Orbiter Wide Angle Camera

The observations made by the *Apollo* sub-satellites were confirmed by NASA's *Lunar Prospector*, the Japanese Space Agency's *Kaguya*, and India's *Chandrayaan-1*: missions designed to map lunar resources, survey topography, and test for lunar gravity and magnetic fields. Data from the *Lunar Prospector* showed that every swirl has a magnetic anomaly that appears to act as a miniature magnetosphere. The data support the idea that the anomalies produce a cavity in the solar wind that somehow protects the exposed silicate materials on the lunar surface from space weathering.

This idea was tested by researchers at the Rutherford Appleton Laboratory in the U.K., who used a solar wind tunnel to study the interaction of small magnetic bubbles with a jet-like stream of charged particles. They found that the stream of particles created an electrostatic field that protected an underlying exposed surface (Figure 3) at the edges of the magnetic bubble. The research demonstrated that the interaction of the solar wind with the magnetic-field anomalies could create protected areas on the surface of the Moon, thereby

helping to produce the swirls. We seem to know how dust moves around, and how the dust is protected from the solar wind by the magnetic anomalies on the surface of the Moon, but there are still some interesting questions left to study.

Now that you know what to look for, go out and do just that—take a look. ★

Dave Garner teaches astronomy at Conestoga College in Kitchener, Ontario, and is a Past President of the K-W Centre of the RASC. He enjoys observing both deep-sky and Solar System objects and especially trying to understand their inner workings.

Figure 3 — A stream of charged particles flows around a magnet in a solar-wind tunnel experiment, creating an electric field that protects the magnet from the beam. Image Credit: R. Bamford, Rutherford Appleton Laboratory

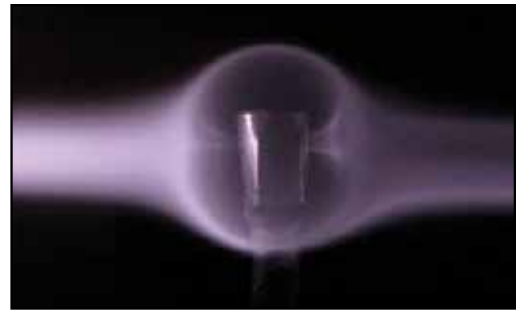

Through My Eyepiece

Binoculars or Telescope?



*by Geoff Gaherty, Toronto Centre
(geoff@foxmead.ca)*

Many newcomers to astronomy are troubled with the decision of what instrument they should buy. Most automatically assume that astronomy requires a telescope. On the other hand, many beginners' books suggest that binoculars are a better first instrument. Our late friend Leo Enright insisted that neither was necessary, and that we should first learn our way around the sky with nothing but our eyes.

Thanks to light pollution, naked-eye astronomy has become something of a lost art. I'm lucky enough to live on a farm, where I can see the Milky Way on any clear moonless night, but the majority of mankind isn't as lucky. Most of us must contend with a greater or lesser degree of man-made light pollution. In some ways, a moderate amount of light pollution actually helps a novice by blocking out the "noise" of thousands of fifth- and sixth-magnitude stars and allowing the brighter constellation patterns to stand out.

Only under a truly dark sky do some of the subtler constellations emerge. This is especially true of lengthy winding constellations like Draco, Hydra, and Eridanus. These constellations only become real under dark skies.

Most of us are techies at heart, so inevitably we begin to think of hardware to help us appreciate the skies. The traditional recommendation of binoculars over a telescope was good before light pollution became so all-pervasive. Nowadays, the urban or suburban astronomer really can't see much more with binoculars than he or she can with the naked eye. For the average city-bound astronomer, a telescope is probably a better first choice.

The traditional telescope objects (Sun, Moon, planets, and double stars) are affected very little by light pollution. These are the things that most novices really want to look at and just about any telescope will do. The planets are a different matter. Most beginning astronomers have no idea just how small are the planets. They've seen all the pretty pictures from space probes, and expect to see the planets just like that, large and colourful. One of the most frequent complaints I hear from new telescope owners is that their telescopes really don't magnify at all—the planets look just the same in the telescope as they do with the naked eye.

Perhaps beginners buy small refractors based on the erroneous idea, fostered by many older beginners' books, that they are ideal for looking at planets. The truth is that no telescope smaller than about 150-mm aperture can provide satisfying views of the planets. An exception might be made for slightly smaller apochromatic refractors, but few beginners are likely to lay out the necessary amount of money for a first telescope. Certainly, the 60- to 80-mm refractors starting astronomers are likely to purchase are going to give microscopically small images of planets.

It's usually only after beginners have been involved in astronomy for a while that they realize that the most popular observing targets among advanced observers are actually deep-sky objects. They usually discover this after they have bought their first telescope, so of course this telescope is usually totally inappropriate for the deep sky.

What's the best telescope for deep-sky observing? We usually answer: the bigger, the better. But having seen how quickly mega-Dobs become white elephants, I always include the qualification: as big as you can comfortably transport, set up, and, especially, take down at the end of the night. For me, this limit has always been around 250- to 300-mm apertures in Dobs, smaller in refractors and Cassegrains.

I'm particularly fond of telescopes in the 250- to 280-mm range: big enough to show significant detail in the larger

deep-sky objects yet compact enough to transport and to observe with while sitting down. Sitting down to observe for me is not a luxury, but an absolute necessity for steady, clear views. Smaller telescopes just don't satisfy, and larger ones require too many calisthenics to reach the eyepiece.

I've gone on record here several times in my new-found belief that some form of computer finding aid has become almost essential in today's light-polluted skies. This further marks the death knell of binoculars as an aid to star-hopping. They don't show us much in polluted skies, and they're no longer much help in finding deep-sky objects.

Having dropped that bit of sacrilege, let me come to the defense of my lowly 10×50 binoculars. On my recent trips to Australia and California, these were the only astronomical instruments I brought with me. I love small binoculars because they give me such a direct personal connection with the night sky. They are easy to hold, easy to point, and, under dark skies, give me truly remarkable views of the cosmos.

Going from naked eye to 10×50s gives an increase in aperture from 5 mm to 50 mm. That means a 10-fold increase in resolu-

tion and a 100-fold increase in light-gathering power. A similar step upward would require a 500-mm aperture telescope, something few amateur astronomers can contemplate.

Nothing else in astronomy can compare with the sweep of a 10×50 binocular as you follow the Milky Way northward from Sagittarius to Cygnus in a dark sky. Then there's the Andromeda Galaxy and the Pleiades in the Northern Hemisphere, or the Magellanic Clouds and Omega Centauri in the South.

For an astronomer like me, with regular access to dark skies, it's not a question of binoculars or telescope. It must be binoculars and telescope: binoculars for low-power (7× to 20×) wide-field views and a telescope for high-power (40× to 300×) views of small and/or faint objects. There really is no overlap between the two, and serious astronomers will always choose both. *

Geoff Gaberty received the Toronto Centre's Ostrander-Ramsay Award for excellence in writing, specifically for his JRASC column, Through My Eyepiece. Despite cold in the winter and mosquitoes in the summer, he still manages to pursue a variety of observations. He recently co-authored with Pedro Braganca his first iBook: 2012 Venus Transit.

Rising Stars

The Thirty-Metre Telescope—One World in Search of Many



by John Crossen
(johnstargazer@xplornet.com)

Galileo turned Hans Lippershey's telescope from a parlour toy into one of the world's most important scientific instruments. By pointing the telescope skyward, he changed our concept of the Universe and our place in it. Over the years, that telescope has evolved from Galileo's 2.5-inch refractor into ever-larger light collectors with ever-better optics. Along the way, Isaac Newton gave us the reflecting telescope and the largest apertures of all to explore the heavens.

Then came the *Hubble Space Telescope* (HST) to reshape our view again. *Hubble's* stunning leap forward in image clarity from its orbital viewpoint delivered a wealth of new discoveries—and left us tantalizingly close to answering other questions, if we only had a bigger telescope.

Two decades after *Hubble*, we stand on the threshold of yet another breathtaking advance: the Thirty-Metre Telescope (TMT). Canada is a leading player on the international team



Figure 1 — A model of the Thirty-Metre Telescope and its dome.

of scientists, engineers, technicians, workers, and companies that will help bring this massive project to fruition. From its 4200-metre-high perch on Mauna Kea in the Hawaiian Islands, TMT will have nine times the light-gathering ability of the largest telescope currently in use. It will have 12 times the resolving power of the HST. TMT will be 200 times more powerful than any other telescope in the world.

Dr. Luc Simard is a member of the Canadian team, or should I say contribution. He has the challenging task of bringing together the numerous international instrument teams

working on the project. With an estimated price tag of 1.2 billion dollars, no one country can afford the finances or the brain power to complete the entire project, so in the course of his endeavours, Dr. Simard has travelled to, Skyped, phoned, teleconferenced, and emailed nearly every major industrial country in the world. Among his destinations were China, Japan, and India, where teams are working on laser-guide star projectors, primary-mirror segments, and, of course, instruments.

Canada is developing the adaptive-optics system that will give the thirty-metre behemoth crystal-clear vision through Earth's blurring atmosphere. The adaptive-optics (AO) system is being designed by a team at the National Research Council in collaboration with many of our universities. Canada is a world leader in AO technology, and, fittingly, it will be built in this country. An AO system of the same type is currently undergoing tests at the Gemini South Observatory. This system, called GEMS, is producing images that are superior to those of *Hubble*, even with complications brought on by its 8-metre, Earth-bound mirror. Now imagine what 22 additional metres of mirror could do!

If the TMT were in Vancouver, you could see a loonie in Calgary, a distance of 750 km. Or, let's say you could shave the Moon into two million little slices—the TMT would be able to resolve nine of them at a time. I hope the *Apollo* astronauts didn't leave anything embarrassing behind.

Everything about TMT is big. The 30-metre *f*/1 mirror will be composed of 492 individual segments. The dome will stand 56 metres high—taller than a 15-storey building. The diameter of the dome alone is 66 metres. Under the dome, in the centre of the primary mirror, will be an optical flat that rotates to redirect incoming light to any one of a host of instruments placed around the scope. On today's giant telescopes such as Gemini and Keck, some of these instruments are the size of small cars. On TMT, the permanent ones can be the size of a house. But those are technical details—what's most exciting is the scientific picture.

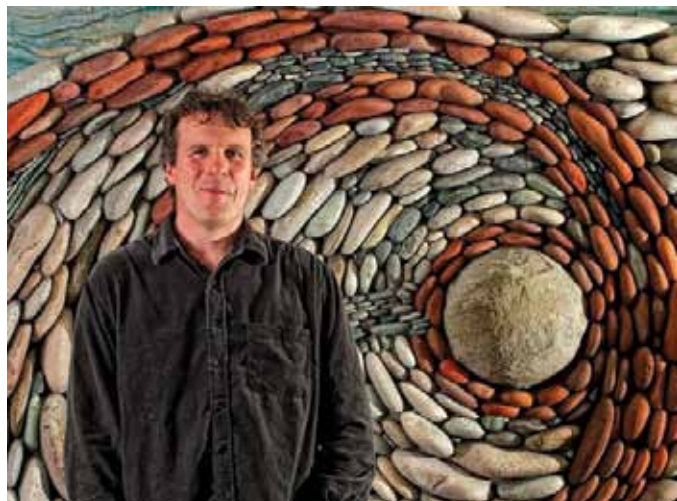

Figure 2 — Luc Simard

TMT will reveal the history of Milky Way evolution. With its immense resolving power, we will be able look further back into time than ever before. It will help us better to understand the nature of dark matter and dark energy, how galaxies, stars, and planetary systems formed. It may even tell us how we came to be. We will be able to image large objects in the Kuiper belt. While the TMT will still be under construction when *New Horizons* sends images of Pluto home, there is a lot more to study in the Kuiper Belt, and TMT will do it. Instead of a nine-year voyage, we will arrive in minutes. Just point the TMT and turn on its instruments.

When distant planets cross the face of their star, just like Venus transited the Sun last summer, we'll be able to use spectroscopy to search for biomarkers—signs of life that tell us there's something or someone else out there. We can see if the exoplanet is green with vegetation, blue with water, rocky, or covered in a thick atmosphere like Venus and Titan. The TMT should break new ground faster than a backhoe.

Those are goals and rewards that will be realized over the years to come. Dr. Simard is also working with more tangible benefits that we can realize today. To him, the overall goal is to bring together the best minds, companies, and skilled engineers in the world with an eye toward turbo-charging future projects, be they telescopes or emergent technologies.

Despite political differences, countries can learn to work together for the common good. Without becoming a big sticky mush, that has to help achieve world peace. The TMT project will result in international contacts and future partnerships between universities and companies that are seemingly unrelated in today's world. Says Dr. Simard, "The bigger the brain pool, the better the end product."

Many technologies being developed and used for TMT are finding their way into down-to-earth applications such as large sports facilities and medical imaging. The math used for analyzing atmospheric turbulence for AO systems incorporates the same algorithms used in CT scans and MRIs.

But that's today. Several of Dr. Simard's duties also involve planning 20 years down the road in terms of additions, improvements, and upgrades to the TMT instruments, even though the first shovel has yet to break ground on Mauna Kea. Completion of the TMT is planned for 2021. It should be quite a party with an international guest list that would rival anything Hollywood could imagine. With five partner countries involved, along with a host of supporting international partnerships, the TMT truly will be one world in search of many more. ★

John Crossen has been interested in astronomy since growing up with a telescope in a small town. He owns www.buckhornobservatory.com, a public outreach facility just north of Buckhorn, Ontario.

Cheap Stuff From China

Power-Distribution Box



by Rick Saunders, London Centre
(ozzy@bell.net)

One thing that I've found I have to carry wherever I'm imaging is a power-distribution box of some kind. In the past, I've had a combination anti-dew controller/12V auxiliary output box running to another unit that took 12V from my battery and dropped it to 5V for a USB hub and 8V for my DSLR camera. I built the circuitry for this myself, and while they all worked well, it was time to cut back on the number of add-on boxes. I had built several other devices using boards or components from China, so I thought I'd see what I could come up with to simplify my power requirements. After some searching on eBay, I managed to find all of the components that I had previously built, for sale at prices so low that I couldn't buy the components for them locally as cheaply. That being the case, I ordered a few bits and pieces and started a new power-distribution box.

The box I had in mind would be for powering the above mentioned hub and camera along with providing a few low-current (< 2 amperes) 12V ports for things like my TOGA intervalometer and TOGA LX guider/focuser box. As most of my cabling already exists, I would use RCA plugs for 12V auxiliary and the 5V hub power and a 3.5-mm mono phone plug to power my camera. I would also be able to monitor the three different voltages via a red LED voltmeter and a three-position guitar switch. All of this would go into an old project case that I happened to have lying around.



Figure 1 — The voltmeter.

The project box I used has a large flat area where the various plugs and switches reside and an angled “face” for the voltmeter. I measured the cutout for the meter in the project box and, of course, made the hole too big. This obligated a new panel part,

which I cut to fit out of some plastic from another old project box. It was ugly looking, but it worked. The panel is held in place with hot glue and a few screws for extra “hold.”

The first part I ordered was the voltmeter. This unit cost under \$2 and shipped free from China (all the parts shipped free). It has three wires: battery positive, battery negative, and sense. The sense wire goes to the voltage you want to measure. The meter requires voltage from 4.5V to 40V with a test voltage from 0V to 99.9V—perfect for this project.



Figure 2 — The variable-voltage board.

I purchased two variable-voltage boards from eBay (\$6 each), only because they're so useful. These are based on the LM2576 SimpleSwitcher chip that has efficiencies of over 80 percent in the voltage and current range that I will be using. Twelve volts from the battery connects to two “IN” pads on the board, and the output voltage comes from two “OUT” pads on the other end. The voltage is adjustable using a small screwdriver to turn a screw on a large, blue, variable resistor. This unit will only provide 1.2A without adding a heat-sink, but my DSLR only draws about 220mA with the shutter open, so I set the board for 8V output. The board was then mounted in the bottom of the case using hot glue, as there were no stand-off holes provided. I pulled the legs out of a chip socket and glued it to the board then roughed up the case with a Dremel and glued the unit into the case. I don't think it'll fall out.

I now needed to provide 5V for my USB2 hub. This is only a 4-port unit, so I need a minimum of 2A for devices and a few milliamps for overhead. On eBay, I found a 12V in/5V out automotive device that will provide 3A at 5V. Perfect! These were designed to allow people who drive Hondas with stickers all over them to put purple LEDs underneath (I don't know why so don't ask). They're not adjustable and have two sets of wires; positive/negative 12V (battery) and positive/negative 5V. Again, this was glued into the case after first roughing up the bottom of the part and the inside of the case.

The last things that I ordered were three on-on-on guitar switches. These are toggle switches that people use on electric guitars to switch various pickups in and out. They're perfect for my purposes, as they can be used, with a suitable jumper in place, to switch three inputs into a single output. The inputs are the three voltages, 12, 8, and 5 in my case, and the output goes to the sense wire of the voltmeter.

The local parts store provided me with a handful of female RCA plugs, a female 3.5-mm mono phone plug, and a male XLR plug for the power input line (you can use cigarette lighter plugs or whatever).



Figure 3 — 5V power for a USB hub, via purple lights for a Honda.

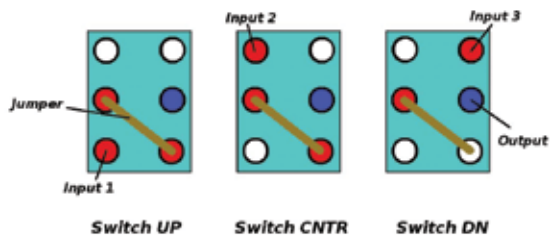

Figure 4 – Switching diagram and jumper location for the guitar switch.

First, I laid out the positions of all of the plugs on the flat of the case using my calipers as a compass and scratching marks. Of course, nothing came out right, but then, I hand cut all the holes. If you have a drill press and hole cutter you could do a better job. I don't, so I have to put up with things being out of line. With the holes cut, I mounted all of the plugs and started wiring.

The 12V aux plugs have all of their centre terminals wired together and all of their ground terminals wired together. The hub-power RCA plug was wired to the 5V power supply and the camera plug was wired to the variable-voltage board. The positive and ground leads from the voltmeter were brought forward to the variable-power board, as this was the simplest place to solder them. The jumper was put on the toggle switch, and then leads to the 12V positive of the variable-power board and the 5V and 8V plugs and the sense line from the meter soldered to the switch's output. The wiring diagram in Figure 5 shows all of the connections.

The next thing to do was to bring 12V in from the battery. I used some fairly thick wire, probably 18 ga that I had lying about and, using the Dremel, made an oblong hole in the side of the box. After bringing the wire through the hole, I wrapped electrical tape on either side for strain relief. I then tied all of the 12V positive wires and 12V ground wires together and soldered and wrapped the whole mess. On the

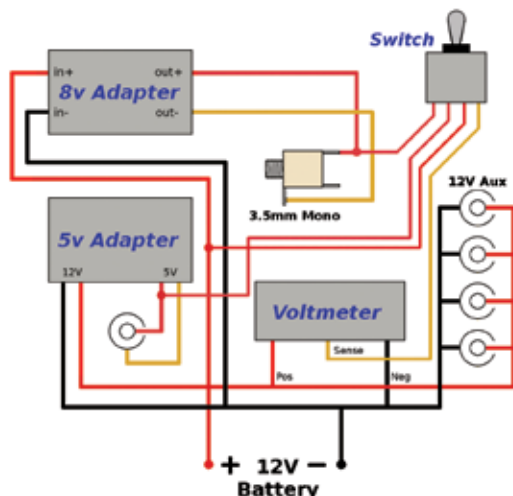

Figure 5 – Wiring schematic.



Figure 6 – The finished power-distribution box.

far end of the 12V wire, I put the male XLR plug, as those are what I use instead of the totally horrible cigarette lighter plugs. The case was finished, and guess what—the smoke didn't come out when I powered it up.

With this unit I have all my low-current power requirements covered in a single unit that ties nicely into my whole power scheme, whether battery powered or using my 13V Walmart power supply. Shown is a picture of the finished unit plugged in and powered up. The old cement floor gives the image some class, don't you think?

The four 12V auxiliary plugs are in two columns on the left and right side of the panel. The bottom row comprises of the 5V plug on the left, the display selector switch, and then the 8V plug. The switch is set to monitor the battery input (12.5V shown).

There really is no “fiddly” work to build this as all of the wires and solder terminals are fairly large. When done, I always check for a short between the inputs from the battery and then check for continuity between all the grounds of the plugs. If those both work out, then normally the smoke will stay in.

In the end, the XLR distribution box was built for a few dollars and connects to all my batteries and AC adapter using a two-wire trailer connector. ★

Rick Saunders became interested in astronomy after his father brought home a 50-mm refractor and showed him Saturn's rings. Previously a member of both Toronto and Edmonton Centres, he now belongs to the London Centre, and is mostly interested in DSLR astrophotography.

eBay Search Strings

Voltmeter	RED LED VOLTMETER
Variable power adapter	LM2576 MODULE
DC-DC 5V step-down	15W CAR LED DISPLAY
On-on-on switch	3-WAY GUITAR TOGGLE SWITCH ON-ON-ON

Second Light

A Revolution in Astronomy



by Leslie J. Sage
(l.sage@us.nature.com)

The plane pitches and yaws in the stiff crosswind above the desert on final approach to Calama, Chile. My adventure to see the inauguration of ALMA, the Atacama Large Millimetre/submillimetre Array, has begun. It has taken 30 years and expenditures of the order of \$1.4 billion USD, but it is almost complete: the instrument that will change modern astronomy beyond all recognition. The incredible power of ALMA was demonstrated on March 13 of this year, when Joaquin Vieira of Caltech and his colleagues from around the world published the detection of molecular gas (carbon monoxide) in a galaxy at a redshift of 5.7 using just 19 minutes of time on ALMA, when only 16 antennae (of a projected total of 66) were online (see March 13 online issue of *Nature*, or the March 21 print issue). To put this detection in perspective, I held the record for highest redshift CO in 1988 for VII Zwicky 31, at a redshift of just 0.05 using about 5 hours of time at the Five College Radio Astronomy Observatory in central Massachusetts.

Although virtually unknown among the general public in the United States, Canada, Japan, and Europe, ALMA is (I predict) going to change astronomy more than the *Hubble Space Telescope*. The people of Chile and Taiwan, who also are partners, are well aware of ALMA and its potential. When a taxi driver taking me to Santiago airport on March 16 asked me what

brought me to Chile, and I told him ALMA, his eyes lit up, and he said that it is an amazing telescope. But first, a brief explanation of why molecular gas is so important in astronomy.

Molecular gas is the stuff out of which stars are made. It is therefore one of the fundamental constituents of any star-forming galaxy. It seems paradoxical when one first thinks about it, but gas has to get very cold and dense before it can form stars. The gas traced by the famous 21-cm line of atomic hydrogen can cool to only ~ 100 K (-173 °C), far above the ~ 10 K (-263 °C) needed for star formation. Observations of carbon monoxide can substitute for hydrogen and, at the same time, permit scrutiny of much colder regimes in the molecular clouds. The CO molecular gas was unknown until 1970, when Phil Solomon suggested to Bob Wilson and Arno Penzias of Bell Labs that they look for lowest rotational transition of the carbon-monoxide molecule (CO) using a technique called position switching. Wilson, Jefferts, and Penzias found the CO emission, and the era of molecular (or millimetre-wavelength) astronomy was born.

ALMA was first discussed over 30 years ago, just before I became Phil Solomon's graduate student at Stony Brook. The original conception was a more modest array, but over the years, and as more partners joined with the National Radio Astronomy Observatory (NRAO) of the US, ALMA grew into the instrument that was dedicated in March. In the end, it will consist of 25 12-m-diameter dishes contributed by the US, 25 12-m dishes from the European Southern Observatory, four 12-m dishes and 12 7-m dishes from Japan. Achieving the technical requirements, particularly being able to point with an accuracy of ~ 1 arcsec in the strong 10 m/s wind (36 km/hr) that blows almost constantly, was a major feat of engineering. In order to accomplish it, the 12-m telescopes

weigh about 100 tons each. And yet, they can move so quickly—slewing about 15 degrees per second—that they almost dance. More information is available at <https://science.nrao.edu/facilities/alma>.

The inauguration ceremony highlighted some of the science already done, such as the work by Vieira and collaborators. I was amused to hear some of the rewriting of history that each speaker indulged in for audiences back home. But the two highlights for me were the live comments from astronauts Tom Marshburn (American) and Chris Hadfield (Canadian) from the *International Space Station* (see the video on YouTube at www.youtube.com/watch?v=4Cjj1-Xmnhc), and when President Sebastian Piñera of Chile gave the command to move the telescopes



Figure 1 — Several of the US antennae.



Figure 2 — The author with the array in the background. Hats are necessary to avoid sunburn.

at the very end. A greatly condensed version can be seen at www.eso.org/public/videos/eso1312b/

Why do I say that ALMA will change astronomy more than the HST? It has always been the case that when new wavelength bands are opened up, or the sensitivity or resolving power of any telescope is a factor of ten or more better than anything before, we will see things that we never imagined. HST achieved the resolution, but ground-based optical telescopes with adaptive optics have since caught up. The HST is more sensitive than Keck, but mainly because of its resolution. ALMA accomplishes all three at once. Its location at an elevation of 5000 m in one of the driest places on Earth puts it above half the atmosphere—Ethan Schreier of Associated Universities Inc. (the parent organization for NRAO) said, “The best telescope on Earth deserves the best location on Earth.” ALMA is certain to discover things that we have not been able to imagine. That is why astronomers build such instruments.

While I very much enjoyed attending the inauguration, I had the bittersweet feeling of missing Phil Solomon, who lost his battle with cancer about five years ago.

I anticipate that over the next ten years I am going to be writing a lot about ALMA discoveries. This is a great time to be an astronomer. ★

Leslie J. Sage is Senior Editor, Physical Sciences, for Nature Magazine and a Research Associate in the Astronomy Department at the University of Maryland. He grew up in Burlington, Ontario, where even the bright lights of Toronto did not dim his enthusiasm for astronomy. Currently he studies molecular gas and star formation in galaxies, particularly interacting ones, but is not above looking at a humble planetary object.

A More Perfect Heaven: How Copernicus Revolutionized the Cosmos, by Dava Sobel, pages 274 + xiv, 14.5 cm × 22 cm, Walker & Co., New York, 2011. Price US\$28.00 hardcover (ISBN: 978-0-8027-1793-1).



Many readers may be familiar with Dava Sobel's previous works: *Longitude* and *Galileo's Daughter*. Like those award-winning books, *A More Perfect Heaven* is well written and based upon meticulous research. An initial scan of the text reveals a section best described as a dramatization, somewhat in the style of that in Galileo's *Dialogue on the Two Chief Systems of the World*. However, Dava's dramatization is less engrossing. She included it

as a means to augment the lack of documentation related to the relationship between Copernicus and his student, George Rheticus, wishing to convey information she felt was reasonable based upon knowledge gained over years of researching Copernicus.

That said, a lasting impression of *A More Perfect Heaven* is the fascinating detail provided by Sobel that reflects Copernicus's early years and education in Turin, and the positions he held, mainly in the Catholic Church in Frauenburg, all gleaned from records retained by the Church. Copernicus's positions included financial duties and others up to the level of Canon, but excluding the right to give communion. It is clear, as well, that he was well connected within the Church both by birth and achievements, a status that was to become critical in the way he planned to disseminate his revolutionary theory. There was a significant difference between his approach to research dissemination and that of Galileo a century later. Indeed, one might draw the conclusion that he delayed publication of *De Revolutionibus* until near death to avoid the wrath he knew would follow from conservative Church officials. Such wrath was inevitable, given that Lutheranism was spreading in Europe at the time, and his association with Lutherans like Rheticus was both known and deeply frowned upon.

Sobel builds a detailed image of Copernicus and his world—his day-to-day activities, his travels and education, his balancing of clerical duties with astronomical research and observations, his relationship with various individuals, including his housekeeper and mistress, Anna Schilling (who was banned from his home in Frauenburg), and challenges with such mundane items as a contentious bread tariff he imposed through the church bakery. Copernicus was well aware from early in his astronomical researches that he would have to tread carefully in selling his theory. To that end, he

SERVING AMATEUR ASTRONOMERS
FOR OVER 22 YEARS!

toll-free 1-800-580-7160
info@khanscope.com

www.khanscope.com

All Major Brands of Telescopes including:
Meade | Celestron | TeleVue | Coronado | APM
SkyWatcher | William Optics | Rigel | Baader
Nikon | Antares | Telrad | Denkmeier | Equinox
Thousand Oaks | Kendrick | Lunt Solarsystems
TeleGizmos | Ioptron | Sky Pub & Others

NEW | USED | TRADE-INS
WE SHIP CANADA WIDE

**KHAN SCOPE
CENTRE**

3243 Dufferin Street, Toronto, ON M6A 2T2
Phone: 416 783 4140 | Fax: 416 352 1701

cultivated contacts within the Church, e.g. the Bishops of Varmia and Kulin (Tiedemann Giese) and with the well known astrologer, cartographer, and globe maker, Johann Schöner. He took a young, enthusiastic George Rheticus as his only student, with the expectation that Rheticus would support and educate others beyond Frauenburg after his death. His choice is interesting, given that George was a Lutheran and stayed in Frauenburg at considerable risk to both teacher and student.

To cut to the core of the book, the last two or three years of Copernicus's life (and the last chapters of the book) were spent, preparatory to publication, trying to build support for the concept of placing the Sun at the centre of the planetary system. Those efforts included drafting a letter to Pope Paul III and choosing a publisher, Johannes Petreius, and proof reader, Schöner. Rheticus oversaw the preparation of the manuscript, but, toward the end, the progress was slow and proofreading tedious. The proofreading and final stages were handed off to one Andreas Osiander, without Copernicus's explicit approval. Osiander oversaw preparation of the introductory notes. It was then that critical changes were inserted, probably by Petreius, perhaps under pressure from Osiander, such as a warning to readers that the work was a theory and not proven. Even the title was changed, with the addition "of the Heavenly Spheres."

Such changes created great consternation for Rheticus once he received copies of the published work. He gathered as many copies as he could and crossed out the offending passages before sending them to the intended recipients, and immediately set forth to publish a new edition, which is referred to as the Basel Edition. The intrigue and how it was documented is fascinating in its own right.

Of course, Sobel traces the influence of *De Revolutionibus* on astronomy and its foundational role for modern science. She describes the observations and arguments favouring the heliocentric hypothesis that were made by Tycho, Kepler, and Galileo. Although their discoveries added support for Copernicus and his arguments for the concept, it was not until almost 300 years later that definitive proof was achieved with the observation of stellar parallax by Friedrich Bessel, who observed parallactic motion for the star 61 Cygni in 1838.

I highly recommend *A More Perfect Heaven* as one of the more interesting and readable accounts of Nicolas Copernicus's life and work. *

Randall C. Brooks

Recently retired to Windsor, Nova Scotia, Dr. Randall Brooks is the former Vice-President, Collection and Research Branch, Canada Science and Technology Museums Corporation. He is an acknowledged expert on early modern precision instruments of science and their accuracy, and among other works has written a highly respected account of the development of the astronomical micrometer. He continues his research on the history of scientific instruments, and has resumed his position as editor of an electronic journal on the topic, eRittenhouse.

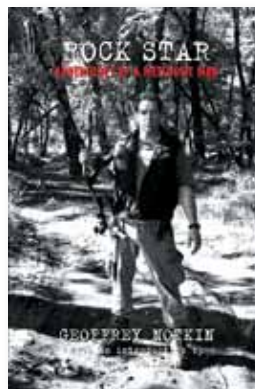

Rock Star: Adventures of a Meteorite Man, by Geoffrey Notkin, pages 252, 22 cm × 15 cm, Stargate Press, Tucson, 2012. Price \$30, softcover (ISBN: 978-0984754823).

Good books and good literature are all about inspiration—they take the reader on a journey beyond the ordinary, and they deliver insights into a world that very few are able to physically experience. The

recent publication, *Rock Star: Adventures of a Meteorite Man* by Geoffrey Notkin, is one such book that delivers with respect to both journey and insights. Along with companion Steve Arnold, Notkin has in recent years become well known in the public domain through the program *Meteorite Men*, and his new book is part biography and part history of how the unlikely television program came about.

In general, I am not an enthusiastic reader of partial, the-story-so-far biographies of people still living—give me

the whole picture, the whole person, and their real achievements, not a collection of disjointed fragments of a life only partially lived. Fortunately, however, these qualms do not really apply to Notkin's latest book. Indeed, here is a story of interest and insight. There is early life biographical detail, engagingly told and revelatory with respect to the Geoff Notkin that most of us first encountered as a TV host traveling the world in search of space rocks. While the biographical details of Notkin's life, thus far, are certainly intriguing, if not surprising, in writing this new book he wisely chooses to focus on the journey, non-linear though it was, leading to his present career as meteorite hunter and dealer through his company, Aerolite Meteorites. Indeed, for me, the best parts of *Rock Star* are those concerned with the expeditions and searches—here is the life that very few people will get to experience. Notkin writes of his feelings and experiences in an expansive manner, using all of his senses to describe the sight, smell, and sound of the place. It is not just about finding meteorites, it is also, perhaps mostly, about the adventure, the realization of boyhood dreams, the awesomeness of the remote landscape, and well, yes, a life lived in both *largo* and *prestissimo* modes, alternating the rhythm as required by the moment.

For Notkin, the world is a stage writ large upon the landscape, and meteorites are the backstage pass. The hunt for fallen space rocks has taken him around the world and found him in the company of many larger-than-life individuals. All of this is engagingly described in some 23 well-illustrated chapters. The reader, well, this reader, was carried along with the story, and particularly felt a strong resonance with the feelings described in Chapter 5, where Notkin writes about his first meteorite find in Canyon Diablo—Devil's Canyon. That first meteorite find is an adventure that no one ever forgets.

Do we get to find the real Geoffrey Notkin in this book? The answer to this question is probably yes and no. We perhaps find the Notkin we might expect as a TV personality—likable, larger than life, obsessive about meteorites, and a long-time science geek (all good qualities, of course). The story of the young, at times rebellious Notkin is set out in some detail, and we find that behind the making of our hero are his parents: a father to instill a love of astronomy; a mother to take him on a life-changing trip to the British Museum of Natural History and its associated Hall of Meteorites—the rest is history. As the book moves through the years, however, the life story seems, perhaps rightly, to become a little more guarded, and somewhat less personal. Certainly, we don't need to know all the details of every job, the new beginnings and life-struggles, but as we approach the Notkin that appears upon our TV screens, less personal detail is revealed; there are snippets and hints, however, and while this occasionally left one asking for more detail, it was, upon reflection, probably more a case of the reader turning away from the act of passive engagement to that of potential stalker. Notkin wisely leaves us wanting more, and perhaps one day we shall receive it. Until that time, however, I

would thoroughly recommend this book to anyone interested in meteorites, astronomy, geology, and just good, old plain fun, exploration, and worldwide adventure. ★

Martin Beech

Martin Beech is a professor at Campion College at the University of Regina with a passion for meteors, meteorites, and the history of science and scientific instruments. Among his articles in the Journal are those that have challenged amateur astronomers to replicate and refine the observations of historical figures. He is a member of the Canadian Space Agency's Meteorites and Impacts Advisory Committee (MIAC), a volunteer group charged with the investigation of fireballs and the recovery of meteorites and one of the sponsors of the Prairie Meteorite Search.

Destination Mars, by Rod Pyle, pages 348, 23 cm × 15 cm, Prometheus Books, Amherst, NY, 2012. Price \$19, softcover (ISBN 978-1-61614-589-7).

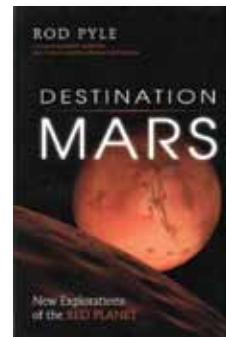

If you love Mars, you probably would love to look over the shoulders of the people who explored it. Rod Pyle introduces you to the myriad of great people who made the Mars missions happen or were instrumental in their success. People have explored Mars vicariously through the eyes and senses of our ingenious creations, from the *Mariners* to the latest, *Curiosity*. A league of extraordinary robots has

provided the eyes, ears, and the many senses that allowed the exploration of the Red Planet. Robots aren't enough though; they in fact are just *dumb* machines with the possibility of greatness. It was the people, the scientists and engineers, who made the journeys possible. They allowed us to step onto another world and see it for the first time. They were the central nervous system urging the small steps forward, plotting the next moves, caught in high drama when things got tense. Rod Pyle's manuscript illuminates the people who made it possible and recounts the missions to Mars in an easy-to-read book.

Rod is the Mars Program Chief Engineer at the Jet Propulsion Laboratory (JPL), and he has been intimately involved with the planning and knows the many people involved in the pursuit of the exploration of Mars. The book is structured around the Mars missions, and interspersed between the chapters on the spacecraft and the voyages, Pyle devotes a chapter to a key person involved with a particular expedition. We get a bit of their background and an interview that illuminates their role with that part of the Mars program. We occasionally hear some of their names in the media, but rarely much more than a technical statement. It is nice to get to know a little bit more about the person behind the scenes and hear what brought them into JPL. It is nicely done.

Society News



by James Edgar
(james@jamesedgar.ca)

As our Society progresses along to our new governance model, we see changes occurring almost daily. Committees are mobilizing forces to create a new balloting system, whereby we can vote electronically for the candidate of our choice at the Annual General Meeting in June. Candidates are being sought out for positions on the Board Transition Committee, people who will act as a Board of Directors until the first election in June 2014. A new Family Membership was initiated at National Council meeting NC131 last March—no longer will we have the “Associate” member, but a system for families that applies equally to all Centres. Another initiative presented to Council was establishment of a Society Policy Manual, one that would identify membership types, for instance, and the numerous categories of policy not carried in the By-Law.

To help explain these numerous and important changes to Centre councils, the By-Law Roadshow will come to your Centre, either in person or via the Internet. One or more of the Executive or Past Presidents will make the presentation and answer questions about the implications of the new regulations and the new By-Law as it pertains to Centres. Some Centres have already had such visits.

Finally, we bid farewell to our Marketing Co-ordinator, Kate Fane. She came to our Society office to help promote the *Journal* and stayed on as a full-time staff member, co-ordinating our marketing and advertising efforts. Now she moves on to greater things. Thank you for all you have done, Kate; it has been a pleasure to know you! ★

Is your address correct?

Are you moving?

If you are planning to move, or your address is incorrect on the label of your Journal, please contact the office immediately.

By changing your address in advance, you will continue to receive all issues of SkyNews and the Observer's Handbook.

(416) 924-7973 | www.rasc.ca/contact

The book starts off with the chapter “The First Martian.” In it, we relive the *Viking Lander's* journey to the surface of Mars, with a graphic recount of the operational systems, descent, and the tension in the control room. The date was 1976 July 20, the 7th anniversary of the *Apollo 11* landing on the Moon. History was being recorded. The earlier *Mariner* spacecraft had swept away our illusions of Martians and canals and a different Mars was being exposed. Astrogeology and astrobiology were in their infancy; we were on the brink of a new era—exciting times at JPL.

Later, budget cuts forced the paring back of much of the space program and the “faster, cheaper, better” motto rang down from the administrators. In hindsight, it was a recipe for disaster, and the '90s were not kind to JPL and their Mars missions. A special chapter is dedicated to the “Great Galactic Ghoul,” tragedies of space exploration with a bit of humour thrown in:

It was the Great Galactic Ghoul, the monster that hides somewhere between the orbits of Earth and Mars in our solar system, whose sole purpose is to devour unwary spacecraft and plunge earthbound scientists into despair. And the Ghoul is good at his job.¹

The collision of metric and Imperial systems, limitations in landing-detection algorithms, and other shortcuts and untested schemes cost NASA dearly in the middle years, but in the end caused a change of heart in mission design. Pyle details the failures, and there are quite a few of them! Since that era, there have been many missions that were designed using a diametrically opposite philosophy and that have delivered resounding successes and an extended play that seems to go on forever. JPL's latest lander is newly arrived and its brilliant timing and success suggests great things to come. Alas, the tradition of the “Sharing of Peanuts” was curiously absent in Rod's book. Perhaps in the next edition.

This book is a fine historical summary of all of the Mars missions, and I am glad to add it to my bookshelf. There are 31 chapters in the 170 pages of this book, which makes it easy to pick up and read a chapter or two in a sitting. Rod has an easy-to-read style and it so was a pleasurable adventure. If you are a Mars or planetary-exploration fan, you will enjoy this book. ★

¹ Page 133 chapter 16, paragraph 2

Murray D. Paulson

Murray Paulson is an active member of the Edmonton Centre and a passionate Mars observer, as well as a meteorite collector and salesman. Among his treasured possessions is a fragment of a Martian meteorite that keeps him in closer touch with the Red Planet than is afforded by a telescope.

Great Images

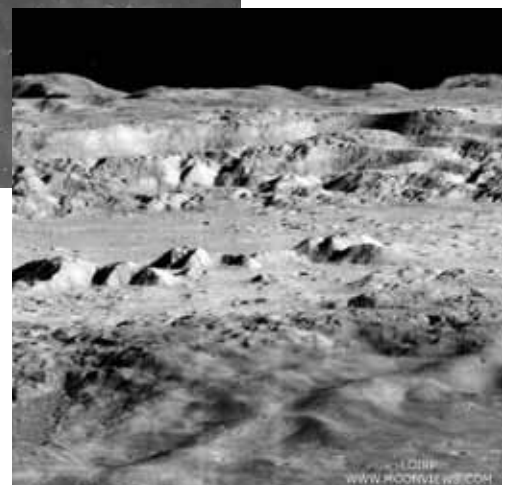
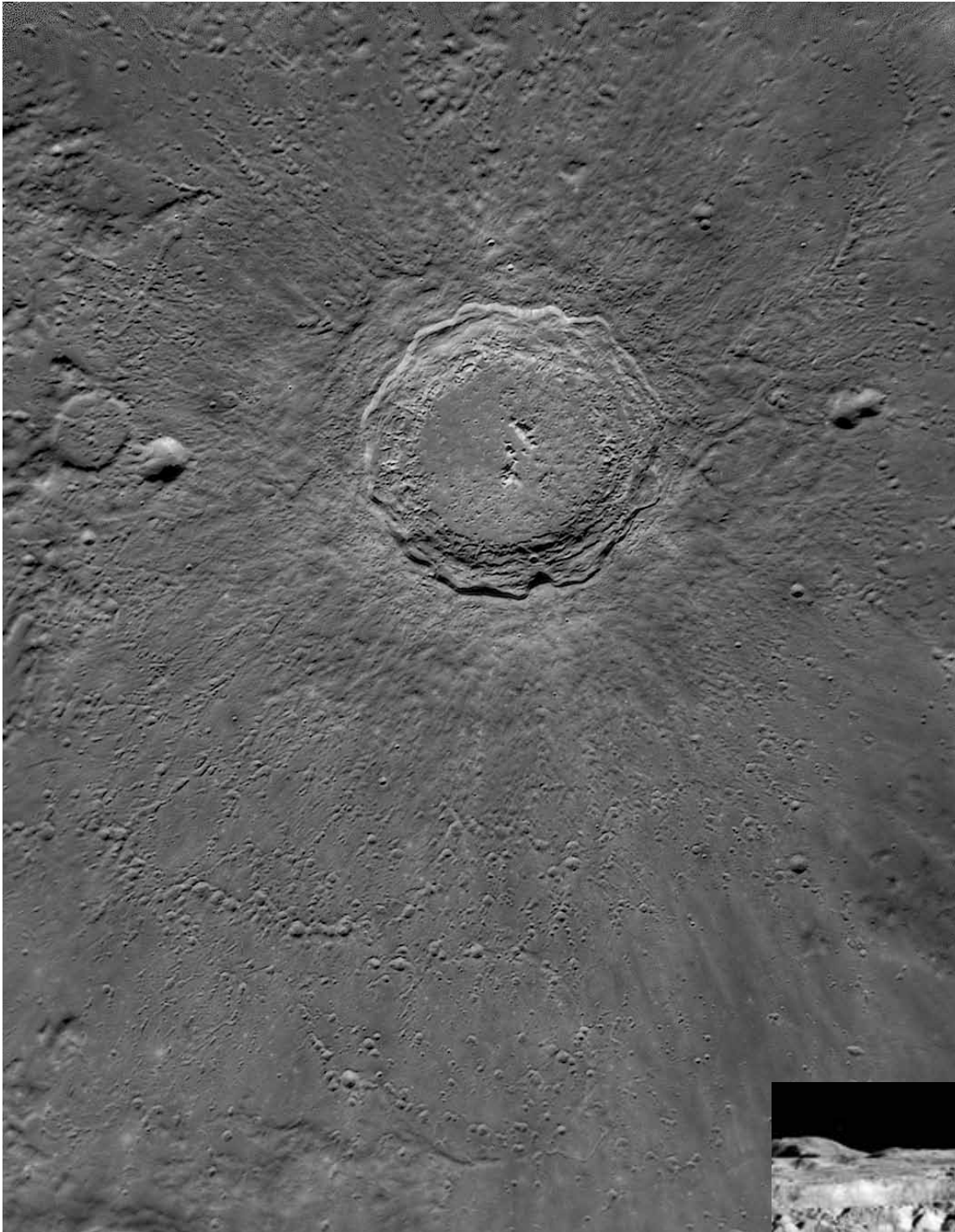

Old-timers will remember the fantastic image of Copernicus (insert) produced by the Lunar Orbiter spacecraft in November 1966 and recently released in digital format (<http://lunarscience.nasa.gov/articles/iconic-lunar-orbiter-image-of-copernicus-re-released>). This above image (the only kind you can get from Earth) by Michael Wirths, brings memories of that 47-year-old photo and its terraces. Even though the sun angle is high, the terrific resolution in Michael's image shows the terraces well, along with the ejecta and rays surrounding the crater. Michael used an 18" Starmaster (ZOC optics) Dobsonian telescope, an ASI120MM camera, and a 2.5x Powermate barlow with an R/IR filter. The image is composed of around 350-500 stacked frames from an original run of 3300.

Astrocryptic

by Curt Nason

ACROSS

1. Devastating sky belch in a blasted city (11)
9. Climaxes seeing the fainter star (5)
10. Stare wildly after an enormous star appears (7)
11. A focal position crossed as soon as my thumb is released (7)
12. Spanish cat rounded Titan first then covered Mars in 2012 (5)
13. Make two charges and revere Leo without a head start (6)
15. Decrease by eleven if Fe+ (4,2)
18. With sodium removed from arsenal, the remnants become coherent (5)
20. Tin star scatters across the zenith (7)
22. Slyly hunt red giant that's not as fast as lightning (7)
23. It's plain below Cerro Tololo (5)
24. Make a mistake in setback before the legal test of earthlike status (11)

DOWN

2. Mount Wilson observer could never completely hum a song (7)
3. Aussie Paul studies neutron stars in the French sky (5)
4. Sunspot observatory around a cheap point (6)
5. A number can turn it green (7)
6. Opportunity's mate lost one on its mast (5)
7. Twinkle in castle lit poorly (11)
8. A cation is so distributed around loosely bound stars (11)
14. Low expansion glass shows Uranus in the wrong order after passing zenith (7)
16. Sun reflects H alpha/beta to a centaur's arrowhead (7)
17. Foul weather forecast for the lunar ocean (6)
19. Sycorax, Pluto, Umbriel, Makemake and Eris initially formed foam (5)
21. Dave Lane's initials are about to be on a planetarium (5)

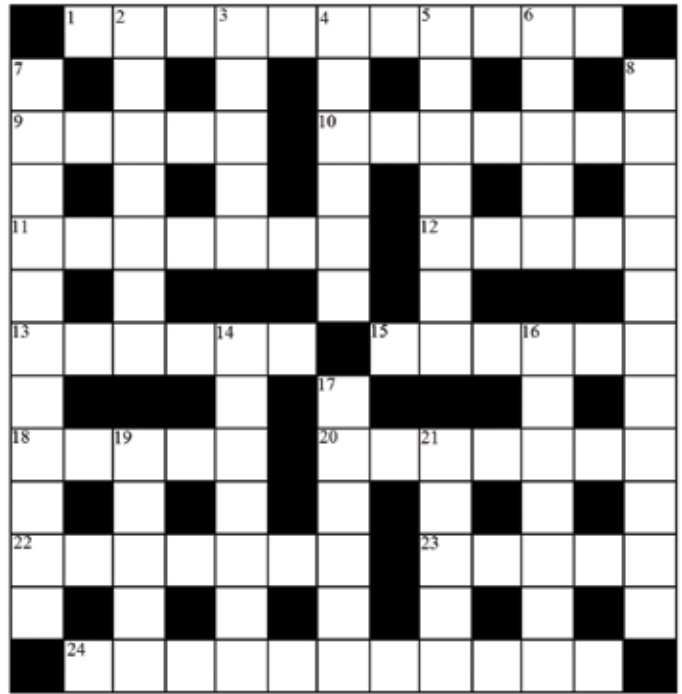

It's Not All Sirius

by Ted Dunphy

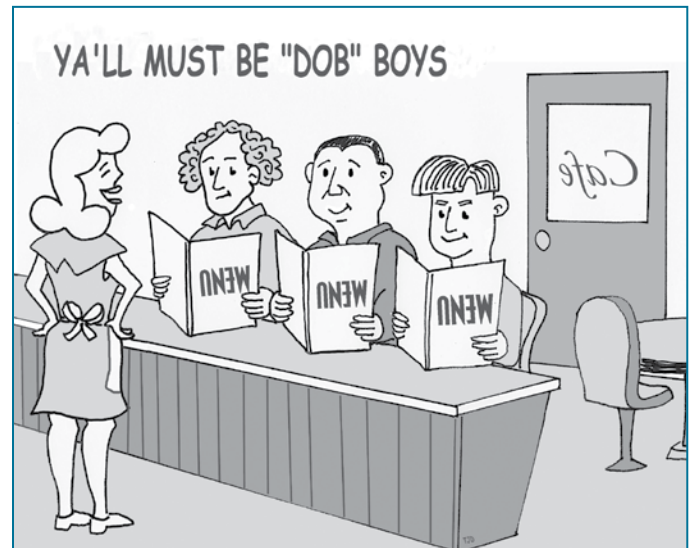

The Royal Astronomical Society of Canada is dedicated to the advancement of astronomy and its related sciences; the Journal espouses the scientific method, and supports dissemination of information, discoveries, and theories based on that well-tested method.

THE ROYAL ASTRONOMICAL SOCIETY OF CANADA

Executive committee and appointed officers for 2013 | Comité exécutif et membres attirés pour 2013

Honorary President	Jim Hesser, Ph.D., Victoria
President	Glenn Hawley, B.Sc., B.Ed., Calgary
1st Vice-President	Colin Haig, B.Sc., M.Sc., Hamilton
2nd Vice-President	Chris Gainor, B.A., M.Sc., Ph.D., Victoria
Secretary/Recorder	James Edgar, Regina
Treasurer	Denis Grey, B. Math., M.B.A., Toronto
Past President	Mary Lou Whitehorne, Halifax
Editor of Journal	Jay Anderson, B.Sc., MNRM, Winnipeg
Editor of Observer's Handbook	David M.F. Chapman, M.Sc., Halifax
Editor of The Beginner's Observing Guide	Brenda Shaw, Toronto
Editor of Observer's Calendar	Paul Gray, Halifax
Executive Director	Deborah Thompson, CAE, Toronto

Centre addresses/Adresses des centres

The most current contact information and Web site addresses for all Centres are available at the Society's Web site: www.rasc.ca

Belleville Centre

c/o Greg Lisk, 11 Robert Dr
Trenton ON K8V 6P2

Calgary Centre

250, 300 5th Ave SW
PO Box 20282
Calgary AB T2P 4J3

Charlottetown Centre

c/o Brian Gorveatt,
316 N Queen Elizabeth Dr
Charlottetown PE C1A 3B5

Edmonton Centre

c/o Telus World of Science
11211 142 St
Edmonton AB T5M 4A1

Halifax Centre

PO Box 31011, Halifax NS B3K 5T9

Hamilton Centre

c/o Mr. A. Blanchard, 2266 Lakeshore Rd W
Oakville ON L6L 1G8

Kingston Centre

PO Box 1793, Kingston ON K7L 5J6

Kitchener-Waterloo Centre

305 – 20 St George St, Kitchener ON N2G 2S7

London Centre

c/o Peter Jedicke, 82 Barrydale Cres
London ON N6G 2X4

Mississauga Centre

PO Box 98011, 2126 Burnhamthorpe Rd W
Mississauga ON L5L 5V4

Centre francophone de Montréal

C P 206, Station St-Michel
Montréal QC H2A 3L9

Montréal Centre

17 Kirkland Blvd, Unit 121
Kirkland QC H9J 1N2

New Brunswick Centre

c/o Emma MacPhee
26 Wilson Rd, Riverview NB E1B 2V8

Niagara Centre

c/o Dr. Brian Pihack
4245 Portage Rd
Niagara Falls ON L2E 6A2

Okanagan Centre

PO Box 20119 TCM
Kelowna BC V1Y 9H2

Ottawa Centre

1363 Woodroffe Ave, PO Box 33012
Ottawa ON K2C 3Y9

Prince George Centre

7365 Tedford Rd
Prince George BC V2N 6S2

Québec Centre

2000 Boul Montmorency
Québec QC G1J 5E7

Regina Centre

PO Box 20014
Regina SK S4P 4J7

St. John's Centre

c/o Randy Dodge, 206 Frecker Dr
St. John's NL A1E 5H9

Sarnia Centre

c/o Marty Cogswell, 6723 Pheasant Ln
Camlachie ON N0N 1E0

Saskatoon Centre

PO Box 317 RPO University
Saskatoon SK S7N 4J8

Sunshine Coast Centre

5711 Nickerson Rd
Sechelt BC V0N3A7

Thunder Bay Centre

286 Trinity Cres
Thunder Bay ON P7C 5V6

Toronto Centre

c/o Ontario Science Centre
770 Don Mills Rd
Toronto ON M3C 1T3

Vancouver Centre

1100 Chestnut St
Vancouver BC V6J 3J9

Victoria Centre

3836 Pitcombe Pl
Victoria BC V8N 4B9

Windsor Centre

c/o Greg Mockler
1508 Greenwood Rd
Kingsville ON N9V 2V7

Winnipeg Centre

PO Box 2694
Winnipeg MB R3C 4B3



Journal

Great Images

Rodney Dingman uses a Meade 8-inch LX200 for his imaging from his back yard in Red Deer, Alberta, and contributes this false-colour image of the Elephant Trunk Nebula (vdb 142) in Cepheus. The image is composed from narrowband filters centred on H α (23 \times 15s), O III (30 \times 20s), and S II (27 \times 15s), using an SBIG 8300 camera.